

VALVES FOR DEHYDROGENATION

SPECIAL VALVES

Taking advantage of its long-standing know-how in designing and supplying special valves for severe operating conditions for metallurgical plants like blast furnaces, **BOMAFA Oil & Gas** today develops, manufactures and distributes special valve solutions for refineries and petrochemical plants.

WEDGE-WITHIN-WEDGE TYPE ISOLATION GATE VALVES

In the field of **Dehydrogenation**, **BOMAFA** offers Wedge-within-Wedge type Isolation Gate Valves tailored to your needs. The Wedge-within-Wedge type Gate Valve is designed for extreme tight isolation under severe operation conditions of high temperature, unequal temperature distribution,

high pressure and high line stresses. In addition its design allows a high frequency of operation and an easy, lowfriction actuation in opening as well as in closing direction.

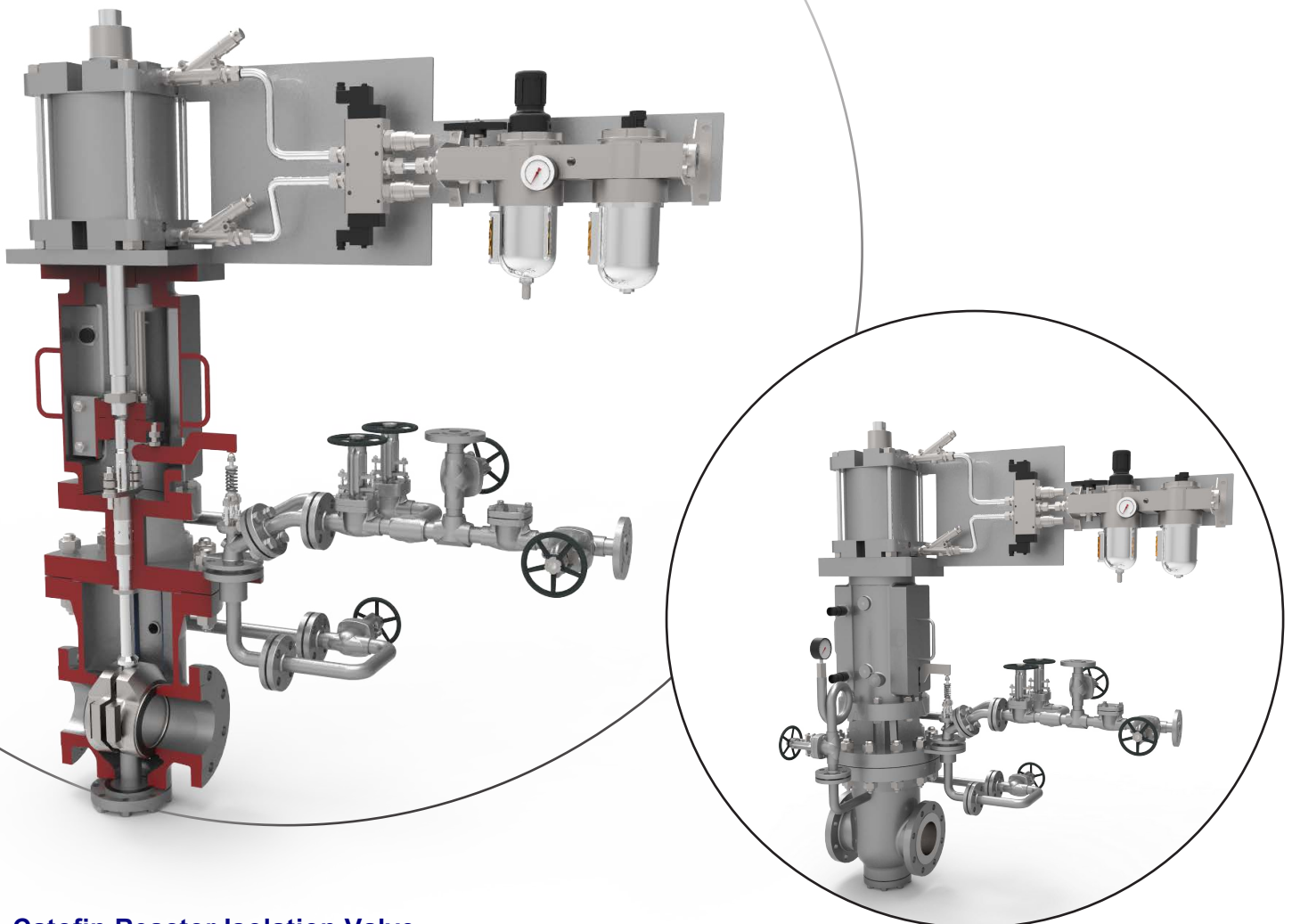

Catofin Reactor Isolation Valve

Key features

- ▶ Double Disc Technology provides positive, tight shut-off by means of active sealing force when shut
- ▶ Double Block and Purge or Double Block and Bleed performance within one valve body
- ▶ High tightness, no jamming or blocking of the valve even under severe temperature differences by means of double wedge design
- ▶ No wear of sealing surfaces due to axial pressing in closed position
- ▶ Valve available in casted design as well as fabricated design, according to customer demands and licensors/customers specifications
- ▶ Electrical, hydraulic or pneumatic options available for valve actuation.



Typical Figures

- ▶ size from 10" (250 mm) up to 80" (2000 mm)
- ▶ operating temperature up to 700° C operating
- ▶ pressure up to 10 bar(g) actuation: electric,
- ▶ pneumatic or hydraulic

Other sizes, design features and / or operating features are available on request.

BOMAF A PRODUCT RANGE - OIL & GAS

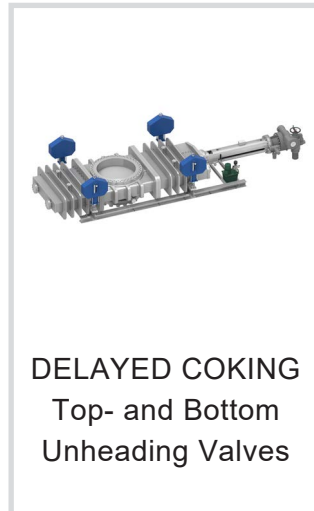
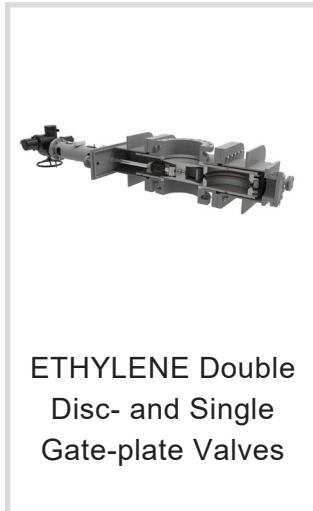

ADDITIONAL PRODUCTS - IRON & STEEL

Goggle Valves, Lever Valves, Double Eccentric Valves, Butterfly and Louver Valves, Dust Outlet Valves, Hot Blast Valves, Tuyere Stocks, Wedge Gate Valves

Push Lever Valves, Snort Valves, Bleeder Valves, Equalizing & Relief Valves, Back Draft Valves, Non Return Valves, Line Blinds

ADDITIONAL SERVICES

Repair Service, Refurbishment and Modifications,
Spare parts for each kind and brand of Valves

The information and specifications contained in this literature are considered accurate. However, they are supplied for informative purposes and should not be considered certified. The products of BOMAFA Group are continually being improved and the specifications, dimensions and information contained in this catalogue are subject to change without notice. For additional information or confirmation, please consult your BOMAFA Group representative.

Quality Management System



ISO 9001-2015

Head Office:

BOMAFA Oil & Gas GmbH

Hohensteinstr. 52
44866 Bochum / Germany

Tel: +49 (0) 2327 992 - 0
Fax: +49 (0) 2327 314 - 43
Email: sales@bomafa.eu
Website: www.bomafa.eu

