

DUST DISCHARGE VALVES ROTATING DISC

DESIGN FEATURES OF DUST DISCHARGE VALVES

- Fabricated construction
- Valve actuation in accordance with customer's requirements (hydr. / pneum.)
- Pressure rating up to 3.0 bar
- Operating temperatures up to 300 °C
- Nominal sizes DN 200 - DN 300
- Other sizes or operating conditions on request

DESIGN ADVANTAGES

- Gas tightness between dust catcher / cyclone and atmosphere
- Flow control into a pug mill / screw conveyor
- High wear resistance
- Low maintenance requirements
- Small overall height

ROTATING DISC VALVE

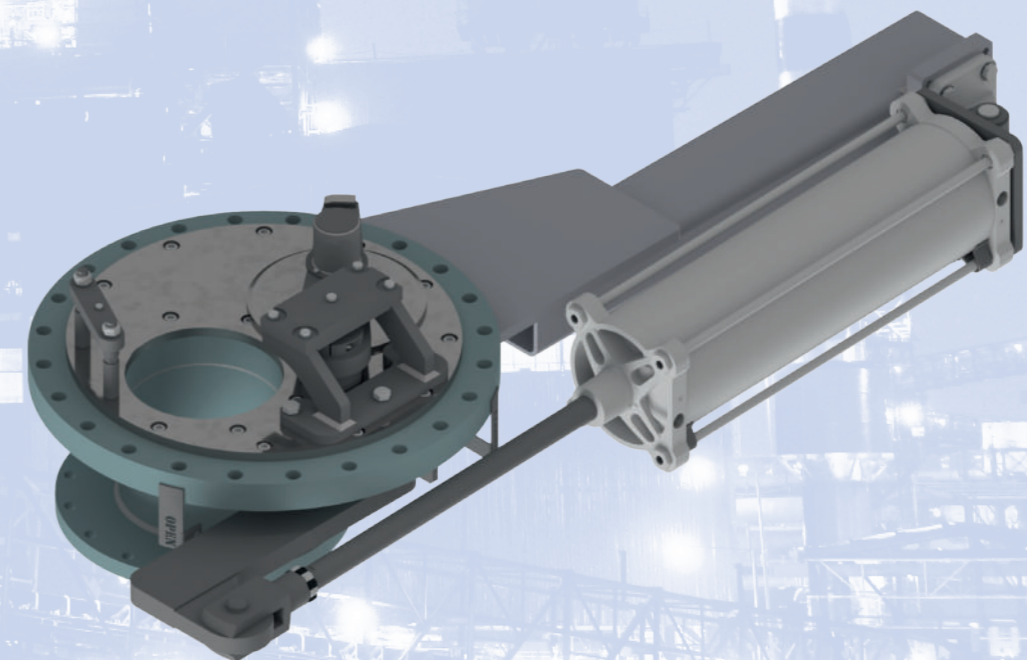
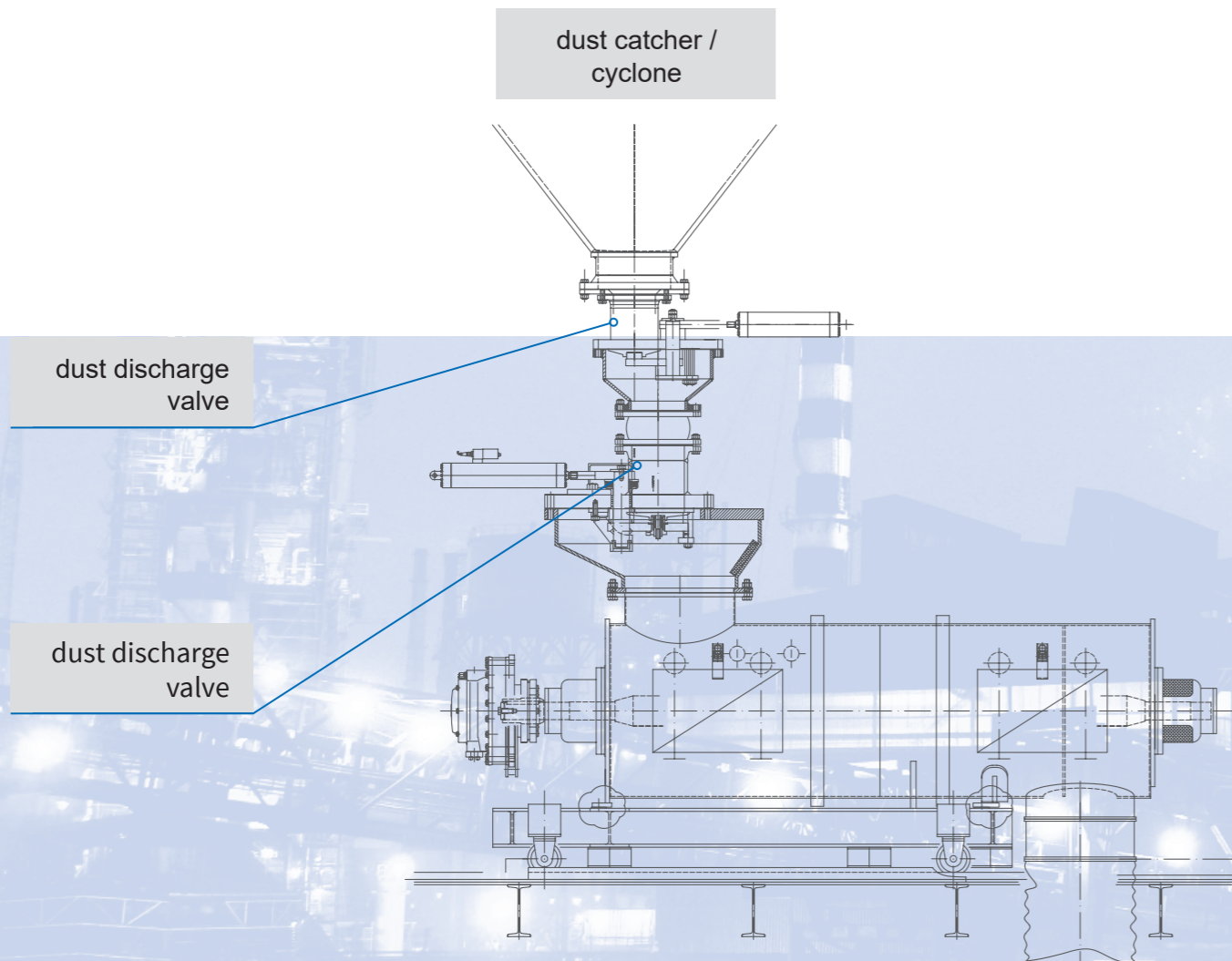
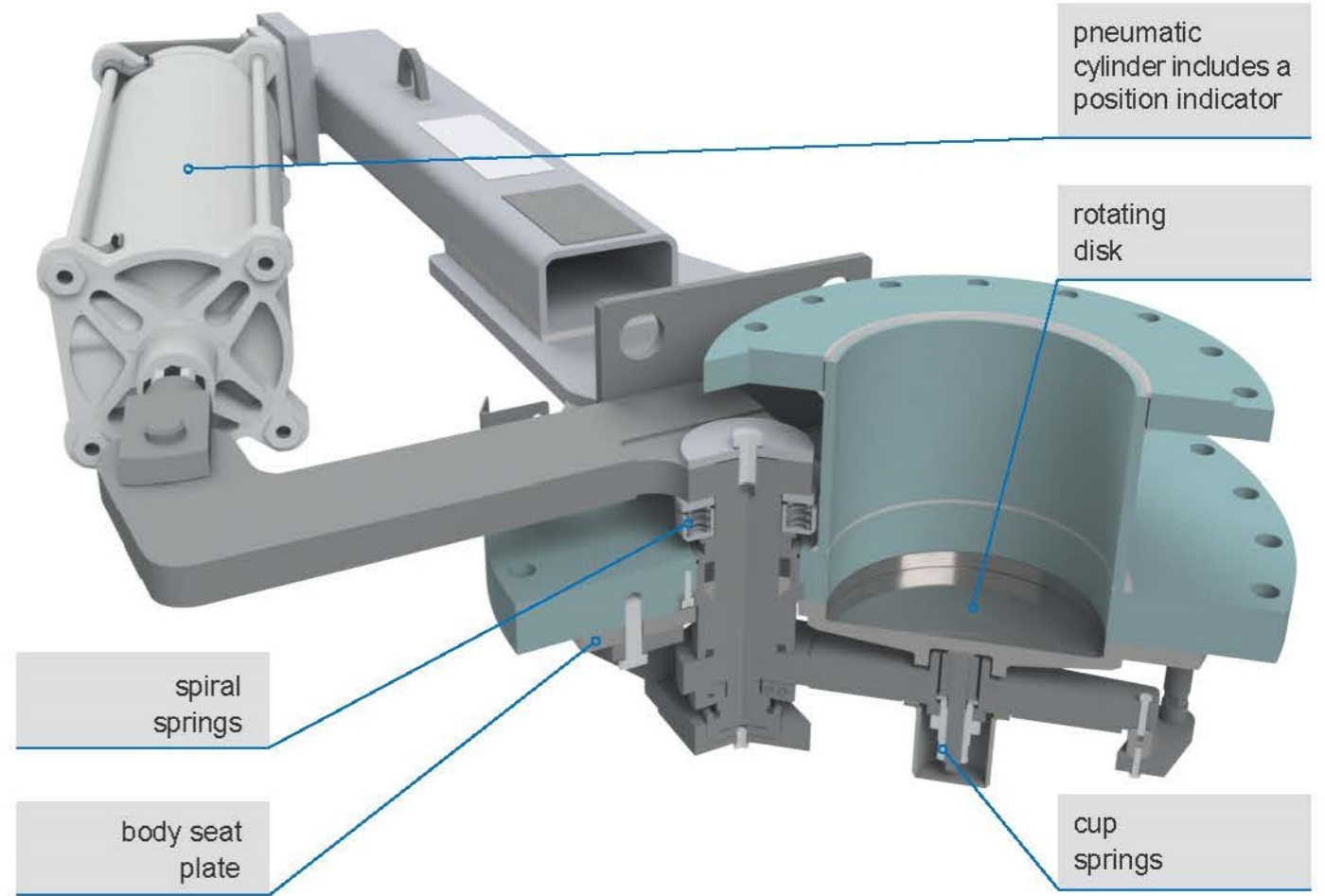

PRODUCT RANGE

GOGGLE VALVES

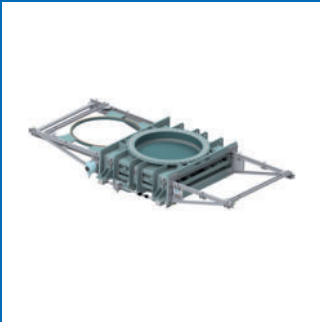

GUIDE LEVER VALVES



DOUBLE ECCENTRIC VALVES

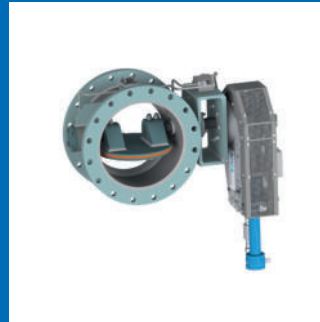

EQUALIZING & RELIEF VALVES



BLEEDER VALVES



**HOT BLAST VALVES
(ENERGY SAVING)**



**TUYERE STOCKS
(ENERGY SAVING)**



WEDGE GATE VALVES

ADDITIONAL PRODUCTS

SNORT VALVES | BACK DRAFT VALVES | BUTTERFLY & LOUVER VALVES
NON RETURN VALVES | LINE BLINDS

ADDITIONAL SERVICES

REPAIR SERVICE | REFURBISHMENT & MODIFICATIONS, SPARE PARTS FOR EACH KIND AND BRAND OF VALVES

The information and specifications contained in this literature are considered accurate. However, they are supplied for informative purposes and should not be considered certified. The products of BOMAFA Group are continually being improved and the specifications, dimensions and information contained in this catalogue are subject to change without notice. For additional information or confirmation, please consult your BOMAFA Group representative.

Quality Management System



ISO 9001-2015

Head Office:

BOMAFA Oil & Gas GmbH

Hohensteinstr. 52
44866 Bochum / Germany

Tel: +49 (0) 2327 992 - 0
Fax: +49 (0) 2327 314 - 43
Email: sales@bomafa.eu
Website: www.bomafa.eu

