

BLEEDER VALVES
BLAST FURNACE SAFETY VALVES

DESIGN FEATURES OF BLEEDER VALVES

- Fabricated construction
- Valve actuation by hydraulic cylinder (standard)
- Pressure rating up to 6.0 bar
- Service temperatures up to 500 °C
- Other sizes or operating conditions on request

DESIGN ADVANTAGES

- Reliable emergency opening (adjustable spring closing device)
- Precise adjustability of opening settings
- Reduced maintenance and improved accessibility of equipment components
- Higher reliability & availability thanks to continuously improved design and customer feedback over several years

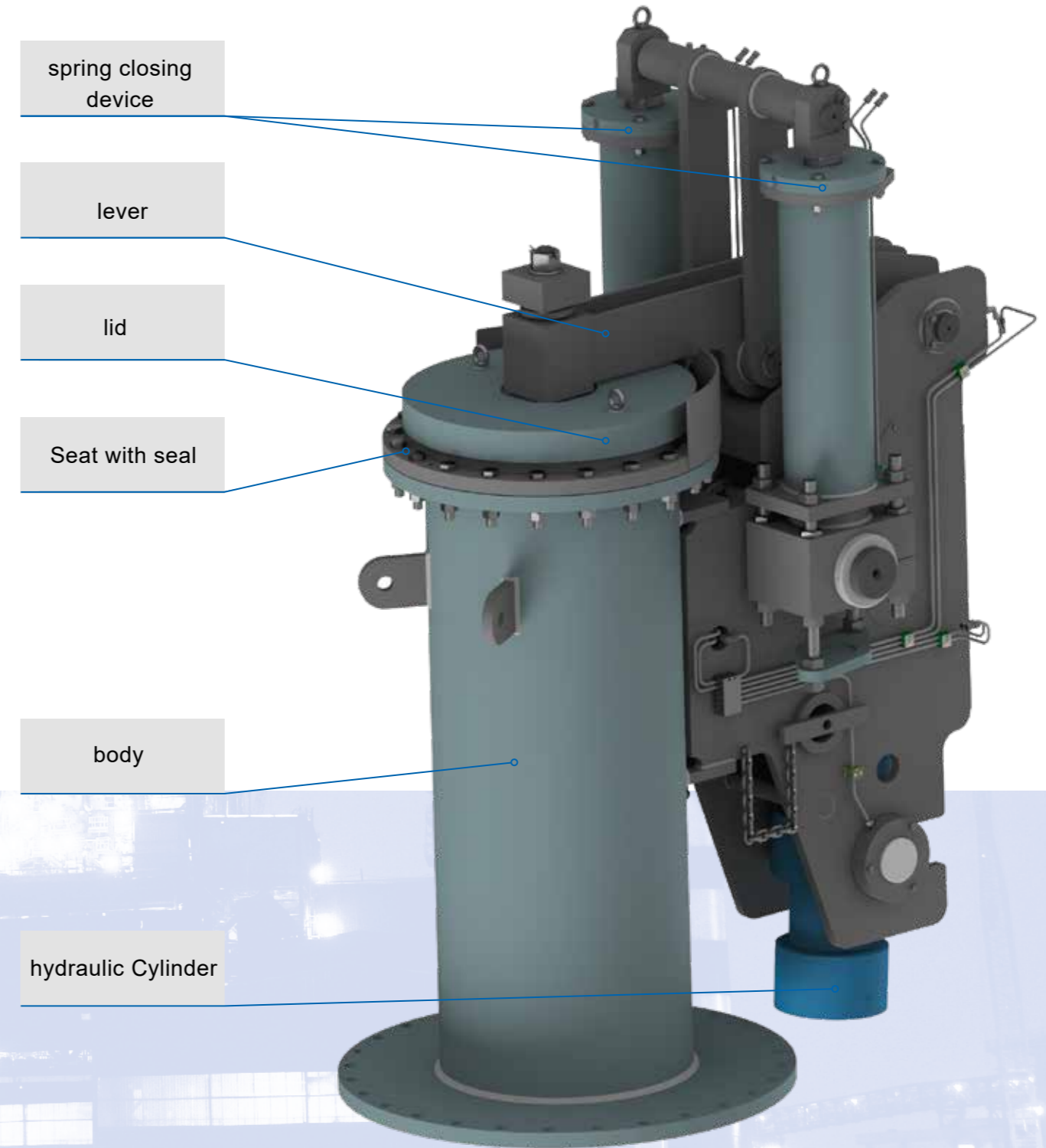

IRON & STEEL PRODUCT RANGE

GOGGLE VALVES



GUIDE LEVER VALVES



**DOUBLE
ECCENTRIC
VALVES**



**EQUALIZING &
RELIEF VALVES**



**DUST DISCHARGE
VALVES**



**HOT BLAST
VALVES (ENERGY
SAVING)**



**TUYERE STOCKS
(ENERGY SAVING)**



**WEDGE GATE
VALVES**

ADDITIONAL PRODUCTS

SNORT VALVES | BACK DRAFT VALVES | BUTTERFLY &
LOUVER VALVES NON RETURN VALVES | LINE BLINDS

ADDITIONAL SERVICES

REPAIR SERVICE | REFURBISHMENT & MODIFICATIONS, SPARE
PARTS FOR EACH KIND AND BRAND OF VALVES

The information and specifications contained in this literature are considered accurate. However, they are supplied for informative purposes and should not be considered certified. The products of BOMAFA Group are continually being improved and the specifications, dimensions and information contained in this catalogue are subject to change without notice. For additional information or confirmation, please consult your BOMAFA Group representative.

Quality Management System



ISO 9001-2015

Head Office:

BOMAFA Oil & Gas GmbH

Hohensteinstr. 52
44866 Bochum / Germany

Tel: +49 (0) 2327 992 - 0
Fax: +49 (0) 2327 314 - 43
Email: sales@bomafa.eu
Website: www.bomafa.eu

