

SINGLE GATE-PLATE VALVE (SGV)

VALVES FOR ETHYLENE PRODUCTION

SPECIAL VALVES

Taking advantage of its long-standing know-how in designing and supplying special valves for severe operating conditions for metallurgical plants like blast furnaces, BOMAFA Oil & Gas today develops, manufactures and distributes special valve solutions for refineries and petrochemical plants.

TRANSFER LINE AND DECOKE LINE ISOLATION VALVES, SINGLE GATE-PLATE DESIGN

In the field of **Ethylene Production**, BOMAFA offers Transfer Line and Decoke Line Isolation Valves tailored to your needs.

The **Single Gateplate type** Gate Valve has a higher tightness and subsequently a higher safety level than other designs. It provides a permanent contact with defined, positive sealing force between the upstream- and downstream valve seats and gate plate by means of precise, mechanical adjustment independent of the medium flow direction.

Key features

- ▶ Double Block and Purge performance within one valve body
- ▶ No springs in use
- ▶ No lift-off in case of back-pressure.
- ▶ Special valve-body design to avoid unequal seat deformation provides :
- ▶ Open throughway without flow restrictions in open position
- ▶ Electrical, hydraulic or pneumatic options available for valve actuation
- ▶ Valve design according to customer demands and licensors/customers specifications

- higher tightness (20% less steam leakage)
- less deformation of the connecting flanges
- less stress to the valve-body welding-seams

> better fatigue performance

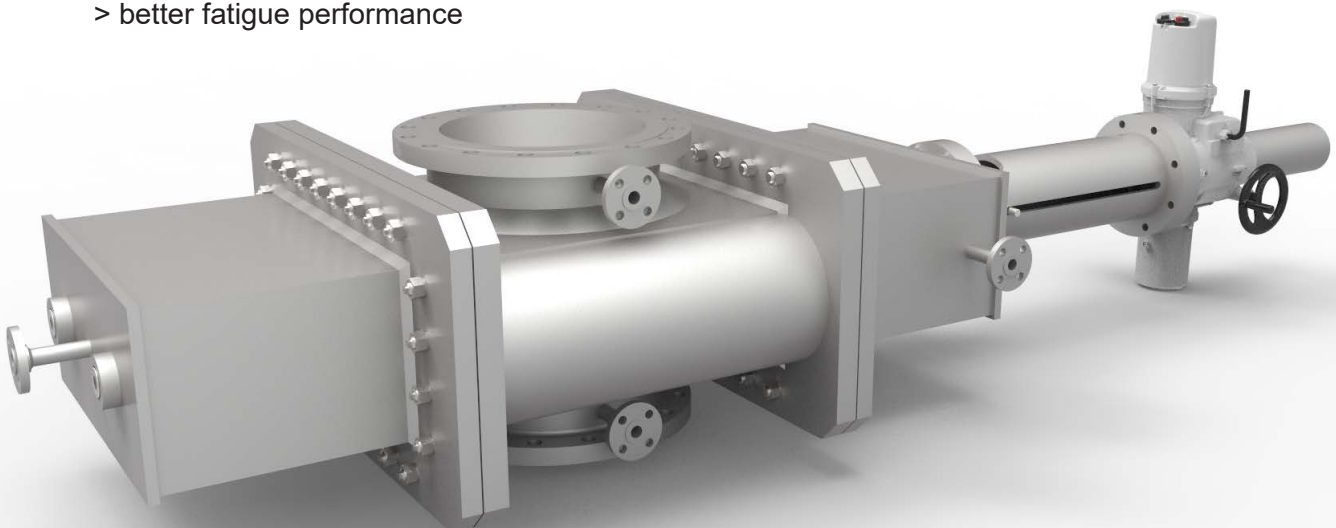

Decoke Line Valve (DV)

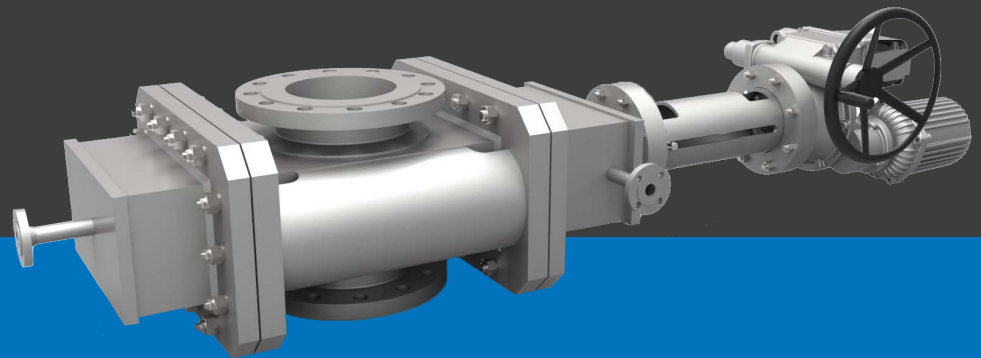
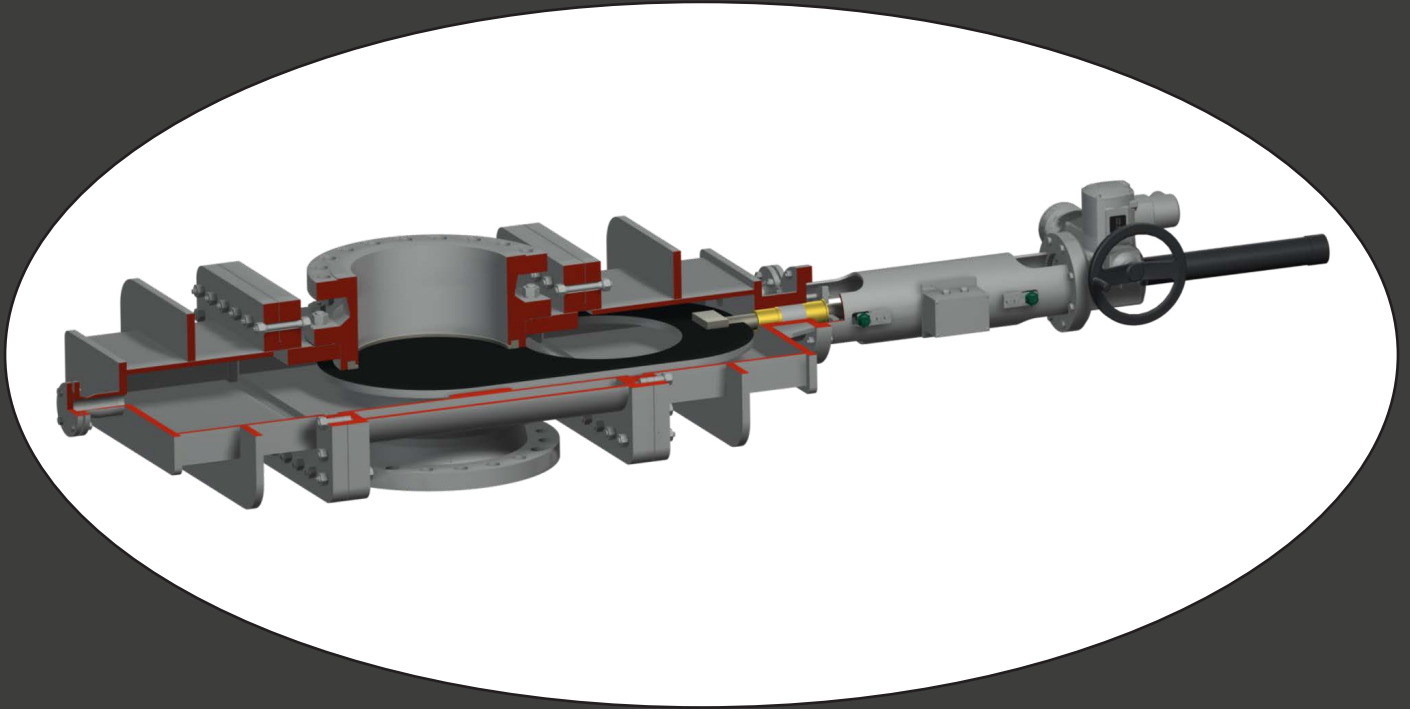

Typical Figures

- ▶ size from 10" (250 mm) up to 58" (1450 mm)
- ▶ operating temperature up to 525° C operating
- ▶ pressure up to 16 bar(g)
- ▶ actuation: electric, pneumatic or hydraulic

Other sizes, design features and/or operating features are available on request.

BOMAF A PRODUCT RANGE - OIL & GAS

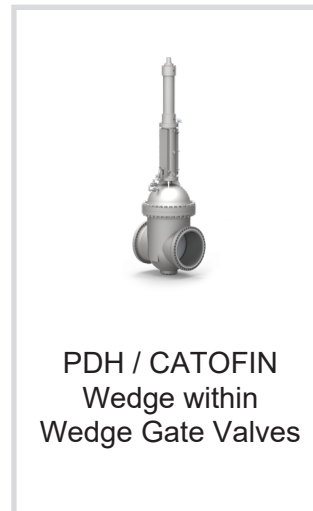

ADDITIONAL PRODUCTS - IRON & STEEL

Goggle Valves, Lever Valves, Double Eccentric Valves, Butterfly and Louver Valves, Dust Outlet Valves, Hot Blast Valves, Tuyere Stocks, Wedge Gate Valves

Push Lever , Snort Valves, Bleeder Valves, Equalizing & Relief Valves, Back Draft Valves, Non Return Valves, Line Blinds.

ADDITIONAL SERVICES

Repair Services, Refurbishment and Modification,
Spare Parts for each kind and Brand of Valves

The information and specifications contained in this literature are considered accurate. However, they are supplied for informative purposes and should not be considered certified. The products of BOMAFAGroup are continually being improved and the specifications, dimensions and information contained in this catalogue are subject to change without notice. For additional information or confirmation, please consult your BOMAFAGroup representative.

Quality Management System



ISO 9001-2015

Head Office:
BOMAFAGroup Oil & Gas GmbH
Hohensteinstr. 52
44866 Bochum / Germany

Tel: +49 (0) 2327 992 - 0
Fax: +49 (0) 2327 314 - 43
Email: sales@bomafa.eu
Website: www.bomafa.eu

