



## V-notch Segmented Ball CONTROL VALVES

## V-notch Segmented Ball Control Valves

The V-notch Segmented Ball Control Valves combines the robustness of globe valves with the typical efficiency of rotary valves. Designed to meet the challenge of controlling industrial processes with muddy fluids, fluids with fibers or suspended particles, the V valve performs precise and reliable control in a wide range of applications in the Chemical, Pulp & Paper, Energy, Oil industries and others. The segmented “V” ball guarantees an excellent operational performance with rangeability greater than 300:1 and allows for exceptional control in gas, liquid and vapor applications. Manufactured in sizes from 1 to 24 inches with carbon steel, stainless steel and alloy steel bodies, the V valve meets ANSI pressure classes 150, 300 and 600, and is designed to operate at temperatures ranging from -50°C to 650°C.



**V Body Subassembly**

# V-Ball Control Valve

## Characteristics and Additional Advantages

The modern design of the V segmented ball control valve by BOMAF A achieves high levels of operating efficiency, versatility and long operating life.

The robustness of its constructive design combined with an entire line of rotary actuators that are compact, light and have high operational performance, and integrated with the advanced Chronos digital positioners form a single tandem in the universe of rotary control valves in numerous industrial processes.

Options	ASME Regulation	DIN Regulation
<b>Sizes</b>	1, 1.5, 2, 3, 4, 6, 8, 10, 12, 16, 20 and 24 in.	DN 25, 40, 50, 80, 100, 150, 200 to 600
<b>ANSI Pressure Class</b>	150, 300 and 600 <sup>(1)(2)</sup>	PN 10, 16, 25, 40 and 63
<b>Ends</b>	Flanged B 16.5 RF RF Separable Flanges Wafer Type	Flanged EN 1092-1 (B1; D; F; B2 Regulation) Separable Flanges Wafer Type
<b>Face to face</b>	ISA 75.08.02	EN 558: 2012-03 Series 36
<b>Body Materials</b>	Carbon Steel ASTM A 216 WCC	Carbon Steel 1.0619
	Carbon Steel ASTM A 216 WCC NACE	Carbon Steel 1.0619 NACE
	Stainless Steel ASTM A 351-CF8M	Stainless Steel 1.4408
	Stainless Steel ASTM A 351-CF3M	Stainless Steel 1.4409
	Stainless Steel ASTM A 351-CF3M NACE	Stainless Steel 1.4409 - NACE
	ASTM A 995 Gr. 6A-CD3MWCuN (Super-Duplex)	Duplex 1.4508
	ASTM A 494 Gr.M35-1 (Monel 400)	Monel 2.4360
	ASTM A 351 Gr. CN-7M (Alloy 20)	Alloy 2.4660
	ASTM A 494 CW-6M (Hastelloy C)	Hastelloy C 2.4883
	ASTM B 367 Gr. C-3 (Titanium)	Titanium 3.7055
<b>Ball Materials</b>	ASTM A 351 CF3M (316L SST)/Hardened Chrome	Stainless Steel 1.4409/Hardened Chrome
	ASTM A 5387 (Solid Alloy 6) Sizes 1" to 6"	Solid Alloy 6, Sizes 1 to 6 in.
	ASTM A 351 CF3M with Alloy 6 coating (HVOF) 8" and above	Stainless Steel 1.4409 / Alloy 6 (HVOF) Size 8" and above
	ASTM A 995 Gr. 6A-CD3MWCuN (Super-Duplex)/Hardened Chrome	Duplex 1.4508/Hardened Chrome
	ASTM A 351 CF (304 L SST)/Hardened Chrome	Stainless Steel 1.4306
	ASTM A 494 Gr. M35-1 (Monel 400)	Monel 2.4360
	ASTM A 351 Gr. CN-7M (Alloy 20)	Alloy 2.4660
	ASTM A 494 CW-6M (Hastelloy C)	Hastelloy C 2.4883
	Titanium B-367 Grade C-3	Titanium 3.7055
<b>Tightness Class</b>	Metal-metal ANSI/FCI 70-2-2006 Class IV Soft Seat ANSI/FCI 70-2-2006 Class VI Flow Ring ANSI/FCI 70-2-2006 Class II	

Notes: (1) Size 16" body ANSI 150-300-600, trims class 150-300

(2) Size 20" body ANSI 150-300, trims class 150

(3) Body 24" Class 150 with 20" trims

# V-Ball Control Valve

## Competitive advantages

The design of the V-ball control valve incorporates the excellent rangeability provided by the segmented “V” ball along with the inherent robustness of the rotary set formed by the shaft, bearings and sealing system.

An unrestricted fluid passage provides efficient control and high flow capacity in gaseous fluids, vapors, liquids and muddy or fibrous fluids.

Characteristics	
One-piece monoblock body	<ul style="list-style-type: none"> <li>■ Eliminates any consequent effects of stresses transmitted by the piping</li> </ul>
Flangeless bodies	<ul style="list-style-type: none"> <li>■ Great cost savings</li> </ul>
Bodies with separable flanges option	<ul style="list-style-type: none"> <li>■ Easy valve alignment</li> <li>■ Cost reductions in exotic alloy bodies</li> </ul>
Integral flange bodies	<ul style="list-style-type: none"> <li>■ Reduction in mounting screws lengths</li> <li>■ Eliminates tension and leakage in case of fire</li> </ul>
Independent bonnet	<ul style="list-style-type: none"> <li>■ Facilitates maintenance, has an internal shaft blowout protection system in accordance with ASME B 16.34 regulation, Section 6.5.1.</li> <li>■ Allows actuator disassembly with the valve installed and pressurized in the pipeline</li> <li>■ Forged, eliminates porosity inherent in castings</li> <li>■ It has great depth and superior internal surface finish</li> <li>■ Allows the installation of extended bonnets</li> <li>■ Allows the installation of all packing models</li> </ul>
“V” ball with cutting action	<ul style="list-style-type: none"> <li>■ Reduces clogging formation</li> <li>■ Excellent cutting effect in fluids with fibers</li> </ul>
Excellent control characteristic	<ul style="list-style-type: none"> <li>■ High precision “V” ball construction providing equal-percentage control characteristic</li> </ul>
Rangeability	<ul style="list-style-type: none"> <li>■ Higher than 300:1</li> </ul>
Tightness	<ul style="list-style-type: none"> <li>■ With metal seats exceeds ANSI Class IV</li> <li>■ With soft seats meets ANSI Class VI</li> </ul>
High flow capacity	<ul style="list-style-type: none"> <li>■ Unrestricted fluid passage provides high flow capacity compared to globe or rotary plug control valves</li> </ul>
Easy seat replacement	<ul style="list-style-type: none"> <li>■ The seat ring assembly set is simple and easy, without the need to remove the ball and shaft set</li> </ul>
Various packing models	<ul style="list-style-type: none"> <li>■ Allows the assembly of several packing models and meets EPA*, Ta-Luft and ISO requirements for fugitive emissions control</li> </ul>
Certification	<ul style="list-style-type: none"> <li>■ NACE</li> </ul>

\*EPA: Environmental Protection Agency

# V-Ball Control Valve Specifications

## Ends

Characteristics		
Nominal Size (in.)	ANSI Pressure Class	Ends
1.0	150-600	<ul style="list-style-type: none"> <li>■ Integral flange, RF, 125-250 RMS</li> <li>■ Flangeless (Wafer), 125-250 RMS</li> </ul>
1.5	150-600	<ul style="list-style-type: none"> <li>■ Integral flange, RF, 125-250 RMS</li> <li>■ Flangeless (Wafer); 125-250 RMS</li> </ul>
2.0	150-600	<ul style="list-style-type: none"> <li>■ Integral flange, RF; 125-250 RMS</li> <li>■ Separable flange, RF; 125-250 RMS <sup>(1)</sup></li> <li>■ Flangeless (Wafer); 125-250 RMS</li> </ul>
3.0	150-600	<ul style="list-style-type: none"> <li>■ Integral flange, RF; 125-250 RMS</li> <li>■ Separable flange, RF; 125-250 RMS <sup>(1)</sup></li> <li>■ Flangeless (Wafer), 125-250 RMS</li> </ul>
4.0	150-600	<ul style="list-style-type: none"> <li>■ Integral flange, RF; 125-250 RMS</li> <li>■ Separable flange, RF; 125-250 RMS <sup>(1)</sup></li> <li>■ Flangeless (Wafer), 125-250 RMS</li> </ul>
6.0	150-600	<ul style="list-style-type: none"> <li>■ Integral flange, RF; 125-250 RMS</li> <li>■ Separable flange, RF; 125-250 RMS <sup>(1)</sup></li> <li>■ Flangeless (Wafer), 125-250 RMS</li> </ul>
8.0	150-600	<ul style="list-style-type: none"> <li>■ Integral flange, RF; 125-250 RMS</li> <li>■ Separable flange, RF; 125-250 RMS <sup>(1)</sup></li> <li>■ Sem flange (Wafer), 125-250 RMS</li> </ul>
10	150-600	<ul style="list-style-type: none"> <li>■ Integral flange, RF; 125-250 RMS</li> <li>■ Flangeless (Wafer), 125-250 RMS</li> </ul>
12	150-600	<ul style="list-style-type: none"> <li>■ Integral flange, RF, 125-250 RMS</li> <li>■ Flangeless (Wafer), 125-250 RMS</li> </ul>
16	150-600	<ul style="list-style-type: none"> <li>■ Flange integral, RF, 125-250 RMS</li> <li>■ Flangeless (Wafer), 125-250 RMS</li> </ul>
20	150-300	<ul style="list-style-type: none"> <li>■ Integral flange, RF, 125-250 RMS</li> </ul>
24x20 <sup>(2)</sup>	150	<ul style="list-style-type: none"> <li>■ Integral flange, RF, 125-250 RMS</li> </ul>

Notes: (1) Separable flanges are available for:

- 2 inches size valves ANSI 150/300
- 3 inches size valves ANSI 150, 300, 600
- 4 inches size valves ANSI 150, 300, 600
- 6 inches size valves ANSI 300, 600
- 8 inches size valves ANSI 300, 600

(2) 24 inches valve body / 20 inches trim set

# V-Ball Control Valve Construction / Seating

## Seat Configuration

The V-ball control valve can be equipped with different seat configurations depending on the application and flow direction. The seat or seat ring assembly, as applicable, is fitted to the valve body through a robust and stable retainer that gives the assembly a long service life, even in corrosive environments.

### Soft Seat

This configuration is used when metallic seat rings cannot be employed due to the formation of roughness in valves with special materials that do not allow the hardening or coating of the ball. This configuration is comprised of a single soft ring and it supports bidirectional flow as well as oxygen or corrosive fluid applications.

Description	Shaft Orientation	Tightness Class
One soft ring	Downstream	IV
One soft ring	Upstream	VI

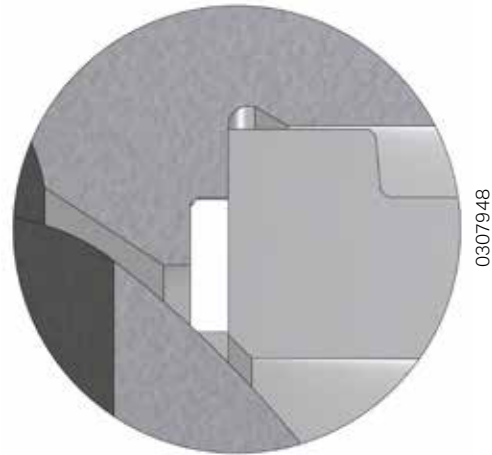

**Soft Seat**

### Dual Seat\*

It is also a standard configuration, composed of a soft seat ring and a metal seat ring.

Description	Shaft Orientation	Tightness Class
One soft ring and one metal ring	Downstream	IV
One soft ring and two metal rings	Upstream	VI

\* Not available for sizes 1 and 1.5 inches.

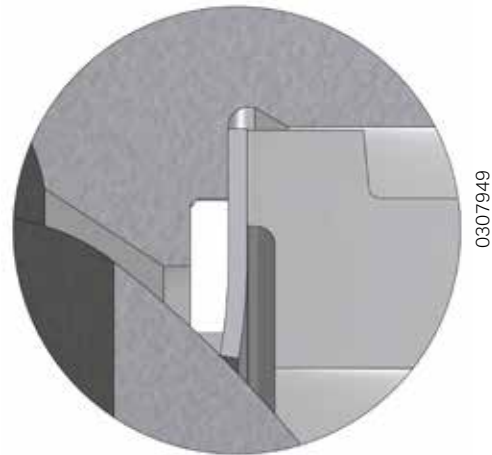

**Dual Seat**

# V-Ball Control Valve Seat Configuration

## Metal Seat

It is the standard configuration, composed of two metal rings, and it permits flow in both directions.

Description	Shaft Orientation	Tightness Class
Two metal rings	Downstream Upstream	IV

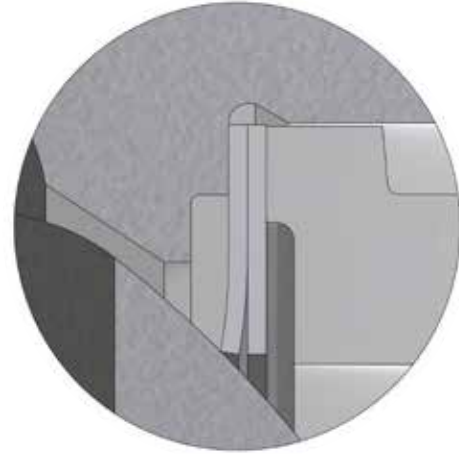

0307951

**Metal Seat**

## Metal Seat - HD

The extra strong HD system is employed in applications with high differential pressure. This seating system consists of a robust metal seat with application of Alloy #6 (UNS S 30006) for the metal version or with a soft material insert ring that works in conjunction with an advanced wave spring system that continuously presses the seat. An O-ring system protects the seat assembly from encrustations that can diminish the operational efficiency.

Description	Shaft Orientation	Tightness Class
Metal ring / spring	Downstream	IV
Metal ring PTFE/PEEK	Downstream	VI

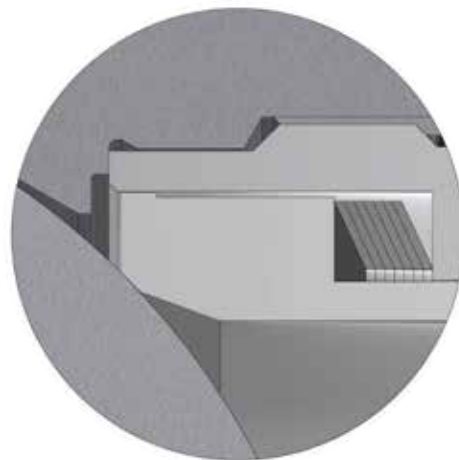

0307953

**Metal Seat - HD**

# V-Ball Control Valve Packing

## Standard Packing

The V-ball valve standard packing is formed by PTFE “V” rings. The PTFE “V” rings are the most used packing system for years, with excellent tightening results. Due to its characteristics of very low friction coefficient, good mechanical resistance and excellent corrosion resistance, it is the most used material for packing systems. The PTFE “V” rings are employed for use in temperatures from -150 to 450°C.

## High Temperature Packing

The V-ball valve packing with molded rings is an alternative to be used when the operational temperature exceeds the limits of the PTFE “V” rings. The materials employed in the V-ball valve molded packing are the braided PTFE, for temperatures of up to 500°C, and the graphite, for temperatures of up to 752°C. The packing with graphite molded rings is an excellent solution for high temperature applications. However, the need of a higher power required for sealing causes a considerable increase in friction in the valve rotation.

## Fugitive Emissions Packing

The PT packing is formed by a set of “V” rings subjected to tightening by a set of spring washers, causing a “live-load effect”. This system reaches a level of tightness below 500 ppm. The PT packing combines the superior quality of virgin PTFE “V” rings and PTFE “V” rings with carbon filaments. The PTG packing is formed by an advanced packing set that is capable of keeping the tightness below 500 ppm (around 10 ppm). The PTG packing is formed by a combination of PTFE “V” rings with carbon filament and Kalrez® “V” rings, an advanced material that provides superior packing performance.

For temperatures above 450°C, the PTG XT packing is employed, as it is formed by Zymax® rings instead of the PTFE rings with carbon.

Standard Packing:  
“V” rings

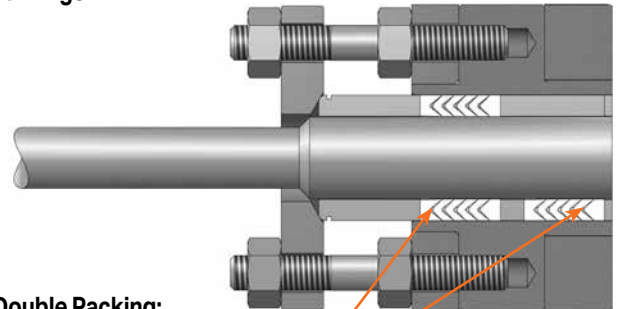

0307132

Double Packing:  
“V” rings

Virgin PTFE

Packing:  
Molded Rings

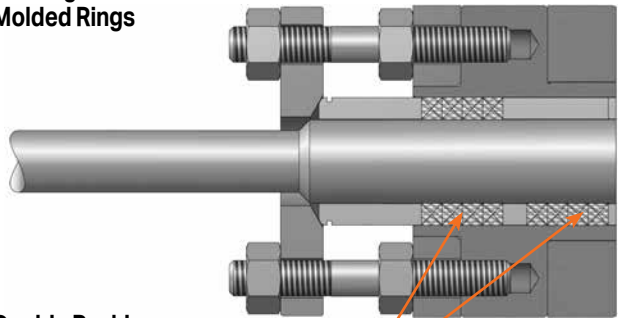

0307133

Double Packing:  
Molded Rings

Braided PTFE or Graphite

PT Packing

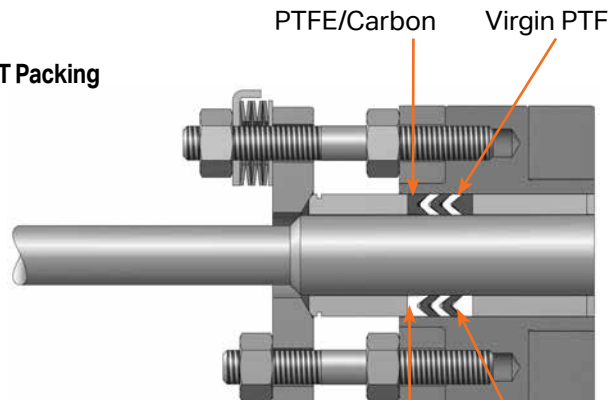

0307134

PTG Packing

PTFE/Carbon or Zymax® Kalrez®



# V-Ball Control Valve Materials Technology Selection

ASTM Material		Temperature Operational Range			
		-50°C	-20°C	450°C	650°C
Body	A 217 WCC		◀ -20°C		
	A 351 CF8M				
	CD3MWCuN 6A				
	494 M35-1				
	351 CN-7M				
	494 CW-6M				
	367 C-3				
Ball	351 CF3M/HC				
	351 CF3M/ Alloy #6				
	Alloy #6 <sup>(1)</sup>				
	CD3MWCuN 6A				
	M 35-1				
	351 CN-7M				
	494 CW-6M				
367 C-3					
Seat	Soft-PTFE		◀ -20°C	425°C ▶	
	Soft-PEEK		◀ -20°C		500°C ▶
	Metal-STD				
	Metal-HD <sup>(3)</sup>				
Bearings	MBT <sup>(2)</sup>			400°C ▶	
	UNS S 31803				
	UNS S 30006				
Post	17-4PH H1075				
	Nitronic				
	Inconel				
Packing	PTFE - "V" Rings			400°C ▶	
	Braided PTFE			400°C ▶	
	Grafoil				
	PT		◀ -29°C	450°C ▶	
	PTG		◀ -29°C	450°C ▶	
	PTG-XT		◀ -29°C)		

Notes: (1) Sizes 1 to 6 in.: Solid Alloy # (UNS S 30006)  
 Sizes 8 in. and above: CF8M (317) w/Alloy #6 (HVOF)]  
 (2) MBT: PTFE/PTFEG inserted in metallic bearing  
 (3) Seat in AISI 316L w/Alloy #6  
 Ball in CF3M (316L) w/Alloy #6

# V-Ball Control Valve

## RA Series Actuator - Specifications

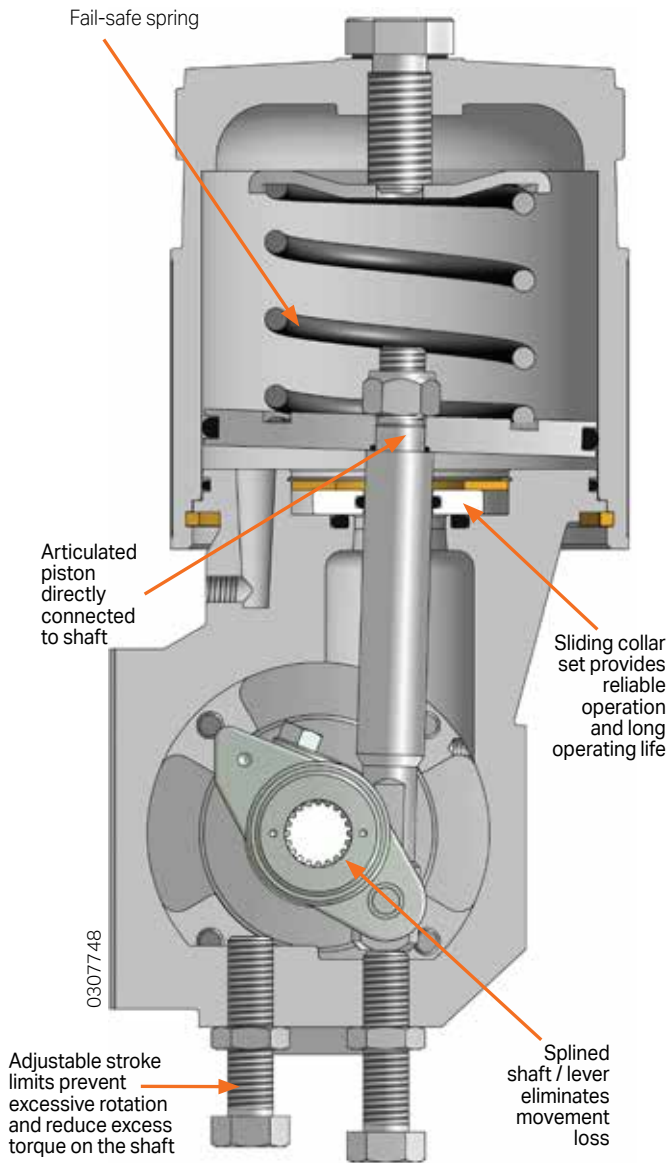

**RA Series Rotary Actuator**

**High interchangeability** – Reduces the need for spare parts

**Compact and light design** – Facilitates handling and occupies limited space

The piston-cylinder rotary actuator with RA series fail-safe spring combines superior torque and pneumatic stiffness with excellent control capacity.

These characteristics are integrated in a light, robust and compact set that is the ideal choice for the actuation of rotary valves.

The RA series double-acting piston-cylinder actuator was designed to operate with supply pressure of up to 150 psi (10.3 bar), reaching a high operational torque. The RA series actuator has a proven service life of a million cycles, making it the most reliable actuator on the market. The double-acting positioner sends air to both cylinder chambers, maintaining an exceptional stiffness. This pneumatic stiffness makes the RA series actuator incomparable and indispensable when precise valve control is required, even when operating with small openings.

All these features guarantee that the RA series actuators deliver a performance much superior than that of the diaphragm and spring actuators.

Specifications	
<b>Type</b>	<ul style="list-style-type: none"> <li>■ Double-acting piston-cylinder with fail-safe spring</li> <li>■ Field reversible</li> </ul>
<b>Sizes</b>	■ 25, 50, 100, 200
<b>Action</b>	<ul style="list-style-type: none"> <li>■ Air-to-open</li> <li>■ Air-to-close</li> <li>■ Fixed in last position</li> </ul>
<b>Air Pressure Supply</b>	■ Maximum 150 psig (10.3 bar)
<b>Operating Temperature</b>	■ -40 to 350 °C
<b>Auxiliary Handwheel</b>	<ul style="list-style-type: none"> <li>■ Side-mounted declutchable</li> <li>■ Gear operated manual</li> <li>■ Lever</li> </ul>
<b>Positioners</b>	<ul style="list-style-type: none"> <li>■ IDP 7600 Chronos Digital</li> <li>■ HPP-2000 Analog</li> </ul>

# V-Ball Control Valve

## RP Series Rotary Actuator - Rack & Pinion Type Specifications

The rack and pinion actuators are excellent options for “on-off” operations, due to its reduced dimensions, light weight and high operational torques. The RP series actuators of BOMAFSA, double-acting with air supply fail-safe spring, robust building and long service life, prevail as the right choice for “on-off” operations.

They are manufactured in extruded aluminum alloy, with internal and external anti-corrosion

protection and internal superficial finishing that assures long operational life and low friction. A double set of racks assembled symmetrically form a set of compact dimensions in accordance to the ISO 5211/DIN 3337 regulations and NAMUR assembly, allowing the easy installation of solenoids, position indicator switches, as well as other accessories.

### Specifications

<b>Type</b>	■ Double-acting rack and pinion type
<b>Sizes</b>	■ 65, 75, 95, 110, 125, 140, 160, 190
<b>Action</b>	■ Air-to-open ■ Air-to-close
<b>Air Pressure Supply</b>	■ Maximum 116 psi (8 bar)
<b>Operating Temperature</b>	■ Standard: -28 to 176°C
<b>Manual Handwheel</b>	■ Declutchable

### Specifications

<b>Description</b>	<b>Materials</b>
<b>Body</b>	■ Struded and anodized aluminum, in the standard version ■ Struded and extra- anodized aluminum for aggressive environments, in the special version
<b>Body cover</b>	■ Aluminum/Epoxy
<b>Pinion</b>	■ Nitrited carbon steel, in the standard version ■ Stainless Steel, in the special version
<b>Piston</b>	■ Anodized aluminum
<b>Piston O-Ring</b>	■ Nitrile rubber ■ Viton
<b>Stroke Bolts</b>	■ Stainless Steel
<b>Assembly Bolts</b>	■ Stainless Steel
<b>Piston Guides</b>	■ Nylon 66 and Molybdenum
<b>Springs</b>	■ Treated carbon steel
<b>Pinion bearing</b>	■ Peek
<b>Accessory Assembly</b>	■ Permits accessory assembly in accordance to international standard: ISO 5211; DIN 3337 and VDI/VDE 3845
<b>Option: High Operating Temperature</b>	■ -28 to 302°C

# V-Ball Control Valve Chronos Digital Positioner



## Interface LCD

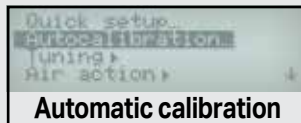

The Chronos IDP7600 positioner is a digital-pneumatic device with microprocessor technology, which employs the HART® (Highway Addressable Remote Transducer) communications protocol for remote communication. The two wire power supply, performed by the control loop itself, significantly contributes for costing reductions at the electrical installation.

The advanced technology provided by the two-stage relay and microprocessor guarantees that the Chronos IDP7600 presents high responsiveness and precise control. With a local PID algorithm with ultra-fast loop execution time and less deviation to set point, this positioner increases significantly the quality in the process control.

Reliability, intuitive use and quick setup and calibration make the Chronos IDP7600 a very functional and advanced HART® positioner. Besides the setup and calibration, which can be performed in the Chronos IDP7600 local interface, the HART® technology allows that the positioner is set and calibrated with the use of software tools based on the EDDL® and FDT/DTM® open technologies.

## Characteristics

The main Chronos IDP7600 characteristics are:

- HART® communication protocol, version 7.
- Temperature and pressure sensors.
- Large and backlit graphical LCD display.
- High bright warning LEDs.
- Quick setup assistant menu.
- Local interface with protected setup buttons.
- DTM with diverse setup parameters, graphics and diagnosis.
- Configurable characterization curve.
- Autocalibration and autotune.
- Automatic or manual gain adjustment of the local PID control.
- Execution of diverse signatures tests, such as ramp test (with friction analysis), step test, multi step test and the valve partial stroke test.
- RFI and EMI immune.
- Explosion proof housing Exd IIC T5/T6 (IECEX/ATEX/INMETRO), IP66
- Advanced two-stage relay technology. Modular design, with the electronic part separated from the pneumatic part.

# V-Ball Control Valve

## Maximum Differential Pressures (psi)

**Flow Direction: Downstream Shaft** <sup>(1)</sup>

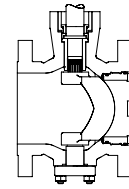

Flow Direction  
Downstream Shaft

Component	Material	Temperature (°C)	Valve Nominal Diameter (inches)								
			1	1.5	2	3	4	6	8	10	12
Shaft and Post	17-4PH (H 1025) (UNS S 17400)	-49 to 84	943	609	450	1479	1059	1030	609	566	943
		86 to 100	943	609	450	1479	1059	1030	609	566	943
		201	899	595	421	1479	1001	986	580	537	899
		300	870	566	406	1450	943	928	551	508	841
		399	812	537	392	1407	885	870	522	479	812
		500	769	508	377	1334	841	827	493	450	769
		599	740	479	348	1218	783	783	464	421	740
	Inconel A 637 (UNS N 07718)	-49 to 84	1102	725	522	1479	1102	1175	696	595	943
		86 to 100	1102	725	522	1479	1102	1175	696	595	943
		201	1073	711	508	1479	1059	1131	682	580	914
		300	1030	682	493	1450	1030	1102	667	566	899
		399	986	653	464	1407	1001	1073	638	551	870
		500	943	624	450	1334	957	1030	609	522	841
		599	885	580	421	1218	899	972	580	493	812
	Nitronic A 479 XM-19 (UNS S 20910)	-49 to 84	798	537	377	1479	769	856	508	435	725
		86 to 100	798	537	377	1479	769	856	508	435	725
		201	638	435	305	1479	566	638	377	319	580
		300	609	406	290	1450	493	580	334	290	537
		399	566	377	276	1407	435	522	290	261	479
		500	522	363	261	1334	392	479	276	247	464
		599	493	334	247	1218	363	435	247	218	435
	Monel K 500 (UNS N 05500)	-49 to 84	870	580	421	1479	566	725	377	334	580
		86 to 100	870	580	421	1479	566	725	377	334	580
		201	812	551	392	1479	537	711	363	319	566
300		798	537	392	1450	537	711	363	319	566	
399		783	522	377	1407	522	696	363	305	551	
500		769	508	377	1334	522	696	348	305	551	
599		754	493	363	1218	508	682	348	290	537	

Notes: 1- The values indicated above are related to the internal components. The pressure/temperature must not exceed the limits of the ANSI B16.34 regulation for the body subassembly.

# V-Ball Control Valve

## Maximum Differential Pressures (psi)

Flow Direction: Downstream Shaft <sup>(1)</sup>

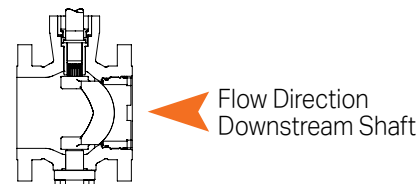

Component	Material	Temperature (°C)	Valve Nominal Diameter (inches)								
			1	1.5	2	3	4	6	8	10	12
Shaft and Post	Alloy 20 (UNS N 08020)	-49 to 84	319	290	203	551	102	174	87	87	261
		86 to 100	319	290	203	551	102	174	87	87	261
		201	261	276	174	450	58	145	58	73	232
		300	232	247	160	406	29	116	44	58	203
		399	189	218	145	363	15	102	44	44	189
		500	160	203	131	319		87	29	29	189
		599	160	189	116	305		87	29	29	189
	Hastelloy B2 (UNS N 10665)	-49 to 84	421	334	247	653	145	232	116	116	290
		86 to 100	421	334	247	653	145	232	116	116	290
		201	377	305	232	609	116	218	102	102	276
		300	348	290	218	566	102	189	87	87	261
		399	305	276	203	522	87	174	87	87	247
		500	276	247	189	464	58	145	73	73	232
		599	247	232	174	421	29	131	58	58	232
	Hastelloy C276 (UNS N 10276)	-49 to 84	276	247	174	464	58	145	73	73	232
		86 to 100	276	247	174	464	58	145	73	73	232
		201	218	232	145	377	29	116	44	58	203
		300	174	203	145	334	15	102	29	44	189
		399	145	189	131	290		73	15	29	174
		500	116	174	116	247		58	15	15	174
		599	87	160	102	203		29		15	160
	Titanium	-49 to 84	334	232	160	725	174	261	145	131	319
		86 to 100	334	232	160	725	174	261	145	131	319
		201	319	218	145	696	160	247	131	116	305
300		305	203	145	638	131	232	116	102	290	
399		276	189	131	595	116	203	102	102	276	
500		261	189	116	522	87	174	87	87	247	
599		247	174	116	32	58	145	73	73	232	

Notes: 1- The values indicated above are related to the internal components. The pressure/temperature must not exceed the limits of the ANSI B16.34 regulation for the body subassembly.

# V-Ball Control Valve

## Maximum Differential Pressures (psi)

**Flow Direction: Downstream Shaft** <sup>(1)</sup>

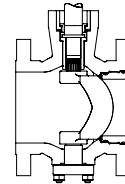

Flow Direction  
Downstream Shaft

Component	Material	Temperature (°C)	Valve Nominal Diameter (inches)								
			1	1.5	2	3	4	6	8	10	12
<b>Seat</b>	PTFE/Tefzel	-49 to 84	928	696	551	247	189	174	174	116	87
		86 to 100	928	696	551	247	189	174	174	116	87
		201	595	595	551	247	174	174	174	116	87
		300	406	406	406	232	174	174	174	116	87
		399									
		500									
		599									
	PEEK/Zymax	-49 to 84	928	696	551	479	377	363	363	232	174
		86 to 100	928	696	551	479	377	363	363	232	174
		201	595	595	551	479	363	363	363	232	174
		300	406	406	464	464	363	348	348	232	160
		399	406	406	464	464	363	348	348	232	160
		500	406	406	464	464	363	348	348	232	160
		599									
	316 SST (UNS S 31600)	-49 to 84	1494	1001	392	363	232	247	261	189	145
		86 to 100	1494	1001	392	363	232	247	261	189	145
		201	1349	899	305	348	232	247	247	174	145
		300	1204	798	290	334	218	232	232	174	131
		399	1131	696	290	305	218	232	218	174	131
		500	1073	595	290	290	218	218	218	174	131
		599	1030	493	276	276	203	218	203	174	131
	Inconel (UNS N 07718)	-49 to 84	1494	1494	769	508	377	363	363	232	174
		86 to 100	1494	1494	769	508	377	363	363	232	174
		201	1450	1436	682	464	363	334	334	232	174
		300	1276	1320	609	450	348	334	319	232	160
		399	1160	1189	406	421	334	319	305	232	160
		500	1117	1073	392	392	334	319	290	218	160
		599	1088	943	377	377	319	305	276	218	145
HD 316 SST	-49 to 84	928	609	450	928	928	928	609	566	928	
	86 to 100	928	609	450	928	928	928	609	566	928	
	201	870	595	421	870	870	870	580	537	870	
	300	827	566	406	827	827	827	580	508	827	
	399	754	537	392	754	754	754	522	479	754	

Notes: 1- The values indicated above are related to the internal components. The pressure/temperature must not exceed the limits of the ANSI B16.34 regulation for the body subassembly.

# V-Ball Control Valve

## Maximum Differential Pressures (psi)

Flow Direction: Downstream and Upstream Shaft <sup>(1)</sup>

Component	Material	Temperature (°C)	Valve Nominal Diameter (inches)									
			1	1.5	2	3	4	6	8	10	12	
<b>Bearings</b>	MBT <sup>(1)</sup>	-49 to 84	928	928	928	928	928	928	928	928	928	928
		86 to 100	740	740	740	740	740	740	740	740	740	740
		201	595	595	595	595	595	595	595	595	595	595
		300	493	493	493	493	493	493	493	493	493	493
		399	377	377	377	377	377	377	377	377	377	377
		500										
		599										
	Ultimet (UNS R 31233)	-49 to 84	928	928	928	928	928	928	928	928	928	928
		86 to 100	928	928	928	928	928	928	928	928	928	928
		201	870	870	870	870	870	870	870	870	870	870
		300	827	827	827	827	827	827	827	827	827	827
		399	754	754	754	754	754	754	754	754	754	754
		500	653	653	653	653	653	653	653	653	653	653
		599	508	508	508	508	508	508	508	508	508	508
	Alloy #6 (UNS R 30006)	-49 to 84	928	928	928	928	928	928	928	928	928	928
		86 to 100	928	928	928	928	928	928	928	928	928	928
		201	870	870	870	870	870	870	870	870	870	870
		300	827	827	827	827	827	827	827	827	827	827
		399	769	769	769	769	769	769	769	769	769	769
		500	696	696	696	696	696	696	696	696	696	696
		599	624	624	624	624	624	624	624	624	624	624

Notes: (1) MBT: PTFE/PTFEG inserted in metallic bearing



# V-Ball Control Valve Maximum Differential Pressures (psi)

Flow Direction: Upstream Shaft <sup>(1)</sup>

Flow Direction Upstream Shaft 

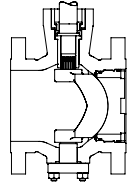

Component	Material	Temperature (°C)	Valve Nominal Diameter (inches)								
			1	1.5	2	3	4	6	8	10	12
Shaft and Post	17-4PH (H 1025) (UNS S 17400)	-49 to 84	1117	638	464	1479	1479	1479	1247	986	957
		86 to 100	1117	638	464	1479	1479	1479	1233	986	957
		201	1073	609	450	1479	1479	1479	1175	943	914
		300	1015	580	421	1450	1450	1450	1117	885	870
		399	972	551	406	1407	1407	1407	1059	841	827
		500	928	537	392	1334	1334	1334	1015	798	798
	Inconel A 637 (UNS N 07718)	-49 to 84	1320	754	551	1479	1479	1479	1233	1001	972
		86 to 100	1320	754	551	1479	1479	1479	1233	1001	972
		201	1276	725	537	1479	1479	1479	1204	972	943
		300	1233	711	508	1450	1450	1450	1175	943	928
		399	1189	682	493	1407	1407	1407	1146	914	899
		500	1117	638	464	1334	1334	1334	1102	885	841
	Nitronic A 479 XM-19 (UNS S 20910)	-49 to 84	972	551	406	1479	1450	1479	943	725	740
		86 to 100	972	551	406	1479	1450	1479	943	725	740
		201	783	450	319	1479	1160	1218	754	537	595
		300	740	421	305	1450	1073	1131	682	493	551
		399	696	392	290	1407	986	1030	609	435	508
		500	653	377	276	1334	914	986	566	406	479
	Monel K 500 (UNS N 05500)	-49 to 84	1030	580	421	1479	1160	1218	754	537	595
		86 to 100	1030	580	421	1479	1160	1218	754	537	595
		201	986	551	406	1479	1146	1204	740	537	580
		300	957	551	406	1450	1131	1189	740	522	566
		399	943	537	392	1407	1117	1175	725	522	566
		500	928	522	392	1334	1102	1160	725	508	551
	Alloy 20 (UNS N 08020)	-49 to 84	522	290	218	1059	218	392	174	145	261
		86 to 100	522	290	218	1059	218	392	174	145	261
		201	464	261	189	943	116	377	131	102	232
		300	421	247	174	885	58	247	102	87	218
		399	377	218	160	827	15	203	73	73	203
		500	348	218	145	798		189	58	58	203
	Hastelloy B2 (UNS N 10665)	-49 to 84	522	334	247	1204	334	493	247	189	305
		86 to 100	522	334	247	1204	334	493	247	189	305
		201	508	319	232	1160	290	450	232	174	290
		300	464	305	218	1102	247	406	189	145	276
		399	450	290	203	1044	189	363	174	131	261
		500	421	276	189	986	145	319	131	116	247
	Hastelloy C276 (UNS N 10276)	-49 to 84	406	261	189	972	131	305	131	116	247
		86 to 100	406	261	189	972	131	305	131	116	247
		201	377	247	160	870	44	247	87	87	218
		300	334	218	160	812	29	189	73	73	203
		399	290	203	145	754		145	44	58	189
		500	232	189	131	711		116	29	29	174
	Titanium	-49 to 84	421	247	174	1305	421	537	290	218	319
		86 to 100	421	247	174	1305	421	537	290	218	319
		201	406	232	160	1262	377	522	261	203	305
		300	377	218	145	1189	319	479	232	174	290
		399	348	203	145	1131	276	435	218	160	276
		500	334	189	131	1102	145	377	174	145	261
	-49 to 84	319	174	116	972	131	305	131	116	247	
	86 to 100	319	174	116	972	131	305	131	116	247	
	201	406	232	160	1262	377	522	261	203	305	
	300	377	218	145	1189	319	479	232	174	290	
	399	348	203	145	1131	276	435	218	160	276	
	500	334	189	131	1102	145	377	174	145	261	

Notes: 1- The values indicated above are related to the internal components. The pressure/temperature must not exceed the limits of the ANSI B16.34 regulation for the body subassembly.

# V-Ball Control Valve

## Maximum Differential Pressures (psi)

Flow Direction Upstream Shaft <sup>(1)</sup>

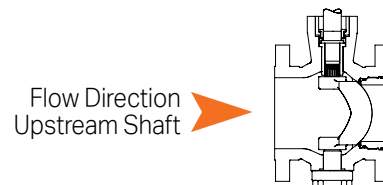

Component	Material	Temperature (°C)	Valve Nominal Diameter (inches)								
			1	1.5	2	3	4	6	8	10	12
Seat	PTFE/Tefzel	-49 to 84	928	609	508	348	276	276	276	276	276
		86 to 100	928	609	508	348	276	276	276	276	276
		201	595	595	508	348	276	261	261	261	261
		300	406	406	406	348	276	261	261	261	261
		399									
		500									
		599									
	PEEK/Zymax	-49 to 84	928	609	508	348	276	276	276	276	276
		86 to 100	928	609	508	348	276	276	276	276	276
		201	595	595	508	348	276	261	276	276	276
		300	406	406	406	348	276	261	276	261	276
		399	406	406	348	348	276	261	276	261	276
		500	406	406	348	348	276	261	276	261	276
		599									
	316 SST (UNS S 31600)	-49 to 84	1479	769	595	595	160	247	218	87	73
		86 to 100	1479	769	595	595	160	247	218	87	73
		201	1479	769	580	580	145	247	218	87	58
		300	1450	769	421	566	131	232	203	87	58
		399	1407	769	421	551	116	218	189	73	58
		500	1334	754	406	537	116	218	174	58	58
		599	1204	754	392	537	87	203	174	58	44
	Inconel (UNS N 07718)	-49 to 84	1479	783	609	624	203	276	247	102	58
		86 to 100	1479	783	595	624	203	276	247	102	58
		201	1479	783	595	609	174	276	232	102	58
300		1450	769	421	609	174	261	232	87	58	
399		1407	769	421	595	174	261	218	87	58	
500		1320	769	406	595	160	247	218	87	58	
599		1218	769	392	580	145	247	218	87	44	

Notes: 1- The values indicated above are related to the internal components. The pressure/temperature must not exceed the limits of the ANSI B16.34 regulation for the body subassembly.

# V-Ball Control Valve Flow Coefficients - $C_V$

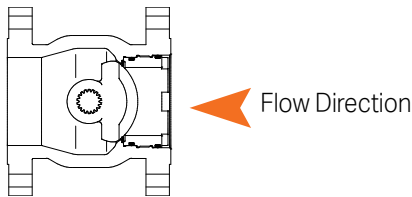

## Flow Coefficients ( $C_V$ ) - Downstream Shaft - Metal Seat

Valve Nominal Diameter (in.)	Trim Area (T/N)	Opening Percentage										
		100	90	80	70	60	50	40	30	20	10	5
1.0	1.0	24	17.3	12.8	9.6	6.9	4.4	2.7	1.38	0.42	0.03	0.001
1.5	1.5	50	37	27	19.3	13.6	8.7	5.0	2.50	0.59	0.08	0.002
2.0	2.0	104	71	50	36	26	17.7	10.7	5.50	1.89	0.14	0.003
3.0	3.0	275	205	142	103	74	51	31	16.2	5.52	0.52	0.010
4.0	4.0	445	319	219	154	105	66	36	20.2	8.10	1.15	0.020
6.0	6.0	844	629	439	322	241	166	107	59	23.4	3.65	0.075
8.0	8.0	1338	955	710	533	385	265	170	95	42	5.80	0.15
10	10.0	2710	2085	1535	1130	825	572	380	230	110	35	1.95
12	12.0	4150	3060	2280	1680	1250	920	635	410	250	110	2.40
16	16.0	7150	5275	3930	2900	2155	1590	1090	705	440	185	4.00
20	20.0	9906	7549	5593	4094	3041	2206	1529	996	622	288	12.50

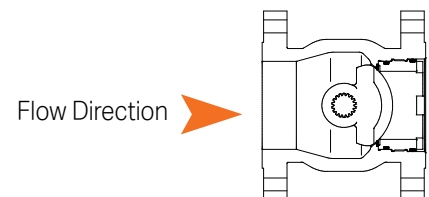

## Flow Coefficients ( $C_V$ ) - Upstream Shaft - Metal Seat

Valve Nominal Diameter (in.)	Trim Area (T/N)	Opening Percentage										
		100	90	80	70	60	50	40	30	20	10	5
1.0	1.0	25	21.5	16	11.5	8.0	5.3	3.0	1.4	0.47	0.08	0.002
1.5	1.5	51	44	33	23.5	16.5	10.5	6.0	2.8	0.81	0.12	0.002
2.0	2.0	107	84.5	59	41	27.5	18.5	11.0	5.3	1.76	0.18	0.003
3.0	3.0	272	233	174	124	82	54	31.5	14.4	4.3	0.41	0.008
4.0	4.0	444	372	278	185	121	73	38	16	7.0	1.00	0.02
6.0	6.0	836	758	600	437	305	197	123	67	27	4.0	0.08
8.0	8.0	1370	1200	928	674	468	310	185	95	38	5.2	0.10
10	10.0	2700	2575	1955	1370	940	620	385	214	98	31	1.70
12	12.0	4150	3220	2700	2090	1490	1010	645	405	245	104	2.15
16	16.0	7150	5550	4660	3610	2570	1740	1115	690	420	180	3.65
20	20.0	9900	7811	6555	5091	3691	2412	1620	1009	612	270	14.4

# V-Ball Control Valve Specifications

## Valve/Actuator Compatibility - Rotary Actuator RA Series

Actuator Size		Valve Nominal Diameter (in.)											
		1	1.5	2	3	4	6	8	10	12	16	20	24x20
25	Std												
25	Ext.												
50	Std												
50	Ext.												
100	Std												
100	HD												
200	Std											O/R	O/R
200	HD											O/R	O/R

O/R: On request

## Valve/Actuator Compatibility - Rotary Actuator RP Series

Actuator Size		Valve Nominal Diameter (in.)											
		1	1.5	2	3	4	6	8	10	12	16	20	24x20
VR - 065													
VR - 075													
VR - 085													
VR - 110													
VR - 125													
VR - 140													
VR - 160												O/R	O/R
VR - 190												O/R	O/R

O/R: On request

# V-Ball Control Valve Dimensions

## Dimensions - Valve with RA Series Actuator and Chronos Positioner ANSI/ISA - 75.08.02

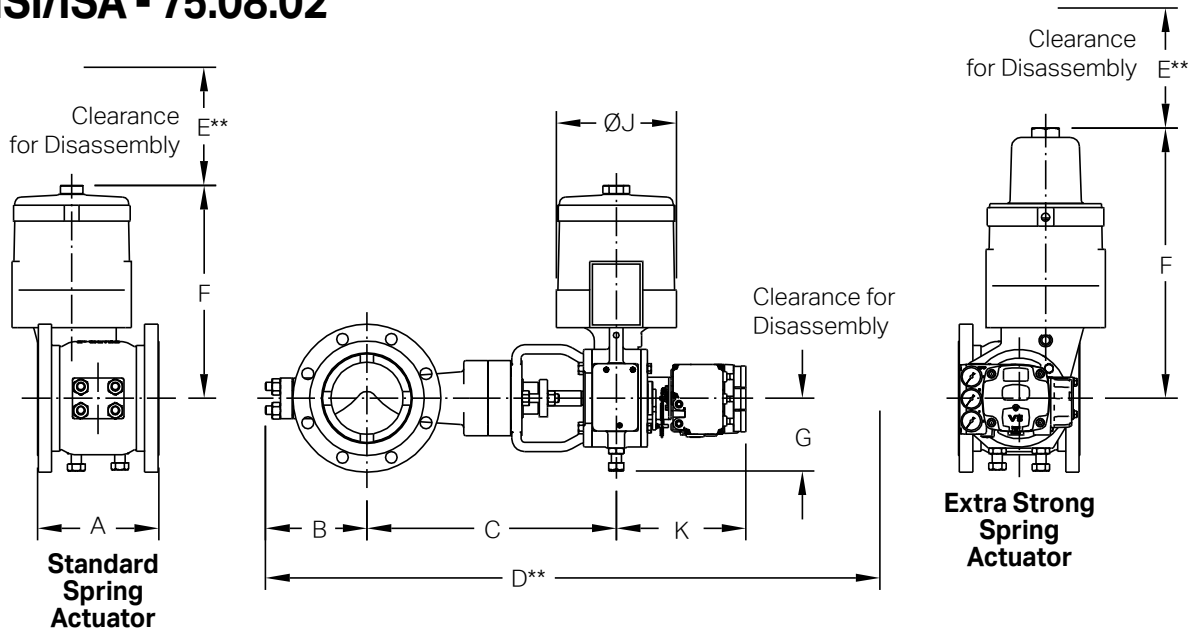

Dimensions																				
Valve Nominal Diameter (in.)	ANSI Class	Actuator Size	A		B		C		D*		F				G		K		E**	
			in.	mm	in.	mm	in.	mm	in.	mm	Standard Spring	Extra Strong Spring	in.	mm	in.	mm	in.	mm	in.	mm
1.0	150-600	25	4.0	102	3.1	79	10.7	272	27.5	699	11.3	286	14.6	370.8	4.6	117	10.4	264	6.0	152
1.5	150-600	25	4.5	114	3.3	84	11.6	295	27.5	699	11.3	286	14.6	370.8	4.6	117	10.4	264	6.0	152
2.0	150-600	25	4.9	125	3.3	84	11.8	300	28.7	729	11.3	286	14.6	370.8	4.6	117	10.4	264	6.0	152
3.0	150-600	25	6.5	165	4.4	112	13.9	354	32.0	812	11.3	286	14.6	370.8	4.6	117	10.4	264	6.0	152
		50	6.5	165	4.4	112	13.9	354	32.0	812	15.8	400	20.8	527.3	5.6	142	10.4	264	8.0	203
4.0	150-600	25	7.6	194	4.9	124	14.5	368	33.0	839	11.3	286	14.6	370.8	4.6	117	10.4	264	6.0	152
		50	7.6	194	4.9	124	14.5	368	33.0	839	15.8	400	20.8	527.3	5.6	142	10.4	264	8.0	203
6.0	150-600	25	9.0	229	4.9	124	18.5	470	35.7	906	11.3	206	14.6	370.8	4.6	117	10.4	264	6.0	152
		50	9.0	229	7.4	188	18.5	470	35.7	906	15.8	400	20.8	527.3	5.6	142	10.4	264	8.0	203
		100	9.0	229	7.4	188	18.5	470	39.8	1012	22.6	574	N/A	N/A	7.3	186	10.6	269	11.0	279
8.0	150-600	50	9.6	244	8.2	208	19.3	490	41.4	1052	15.8	400	20.8	527.3	5.6	142	10.4	264	8.0	203
		100	9.6	244	8.2	208	19.3	490	41.4	1052	22.6	574	N/A	N/A	7.3	186	10.6	269	11.0	279
10	150-600	50	11.7	297	8.2	208	20.5	519	44.8	1138	22.6	574	20.3	527.3	5.6	142	10.4	264	8.0	203
		100	11.7	297	10.8	275	20.5	519	44.8	1138	22.6	574	N/A	N/A	7.3	186	10.6	269	11.0	279
		200	11.7	297	10.8	275	20.5	519	44.8	1138	23.2	589	N/A	N/A	7.3	186	10.6	269	12.6	320
12	150-600	100	13.3	338	11.9	301	21.0	534	46.4	1178	22.6	574	N/A	N/A	7.3	186	10.6	269	11.0	279
		200	13.3	338	11.9	301	21.0	534	46.4	1178	23.2	589	N/A	N/A	7.3	186	10.6	269	12.6	320
16	150-600	100	15.8	400	15.1	384	26.1	663	56.8	1443	22.6	574	N/A	N/A	7.3	186	10.6	269	11.0	279
		200	15.8	400	15.1	384	26.1	663	56.8	1443	23.2	589	N/A	N/A	7.3	186	10.6	269	12.6	320
20	150-600	200	20.0	508	19.0	483	28.1	714	60.8	1544	23.2	589	N/A	N/A	7.3	186	10.6	269	12.6	320

Notes: \* Dimensions with Chronos positioner

\*\* Clearance for disassembly of the standard actuator.

# V-Ball Control Valve Dimensions

## Dimensions - Valve with RP Series Actuator

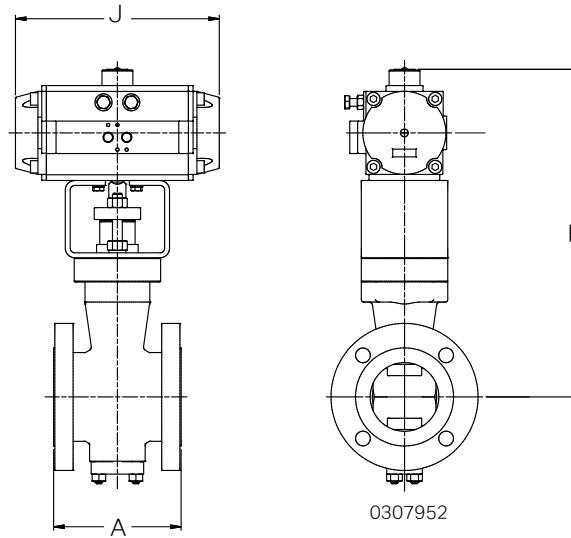

Valve Nominal Diameter (in.)	Actuator Size	Dimensions					
		A		F		J	
		in.	mm	in.	mm	in.	mm
1.0	VR - 065	4.0	102	12.0	305	7.4	189
	VR - 075	4.0	102	12.9	328	8.3	210
1.5	VR - 075	4.5	114	13.9	352	8.3	210
	VR - 085	4.5	114	14.3	363	9.0	229
2.0	VR - 075	4.9	125	13.6	346	8.3	210
	VR - 085	4.9	125	14.0	357	9.0	229
3.0	VR - 085	6.5	165	16.7	423	9.0	229
	VR - 110	6.5	165	17.3	439	10.5	266
4.0	VR - 110	7.6	194	20.4	518	10.5	266
	VR - 125	7.6	194	20.9	530	13.3	337
6.0	VR - 125	9.0	229	24.9	632	13.3	337
	VR - 140	9.0	229	25.5	649	14.8	377
	VR - 160	9.0	229	26.4	671	16.2	412
8.0	VR - 160	9.6	244	26.4	670	16.2	412
	VR - 190	9.6	244	27.6	702	19.2	488
10	VR - 190	11.7	297	29.6	752	19.2	488
	VR - 210	11.7	297	30.5	775	21.7	550
12	VR - 190	13.3	338	31.7	806	19.2	488
	VR - 210	13.3	338	36.7	829	21.7	550

# V-Ball Control Valve Actuator Assembly Guidance

## Standard Right-sided Assembly – Upstream Shaft

Assembly A

AIR-TO-CLOSE: FAIL-OPEN

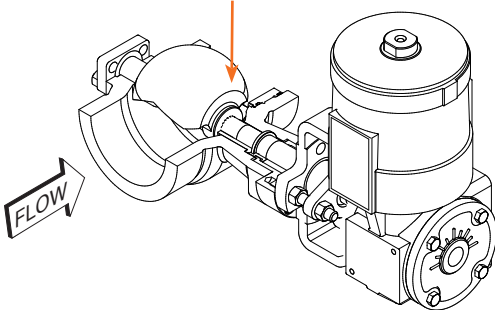

Assembly B

AIR-TO-OPEN: FAIL-CLOSE

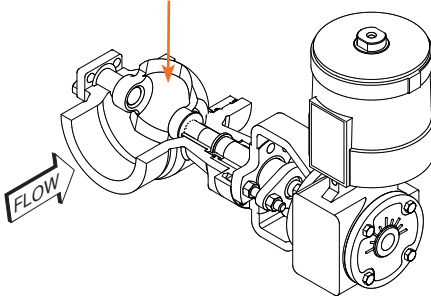

## Standard Left-sided Assembly – Downstream Shaft

Assembly C

AIR-TO-CLOSE: FAIL-OPEN

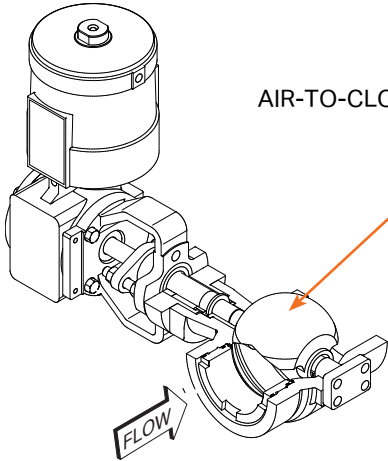

Assembly D

AIR-TO-OPEN: FAIL-CLOSE

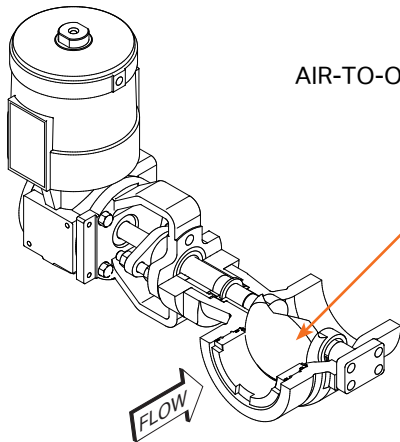

The information and specifications contained in this literature are considered accurate. However, they are supplied for informative purposes and should not be considered certified. The products of BOMAFA Group are continually being improved and the specifications, dimensions and information contained in this catalogue are subject to change without notice. For additional information or confirmation, please consult your BOMAFA Group representative.

## Quality Management System



**ISO 9001-2015**

**Head Office:**

**BOMAFA Oil & Gas GmbH**

Hohensteinstr. 52  
44866 Bochum / Germany

Tel: +49 (0) 2327 992 - 0  
Fax: +49 (0) 2327 314 - 43  
Email: [sales@bomafa.eu](mailto:sales@bomafa.eu)  
Website: [www.bomafa.eu](http://www.bomafa.eu)

