

Control Valves for ultimate performance in all applications

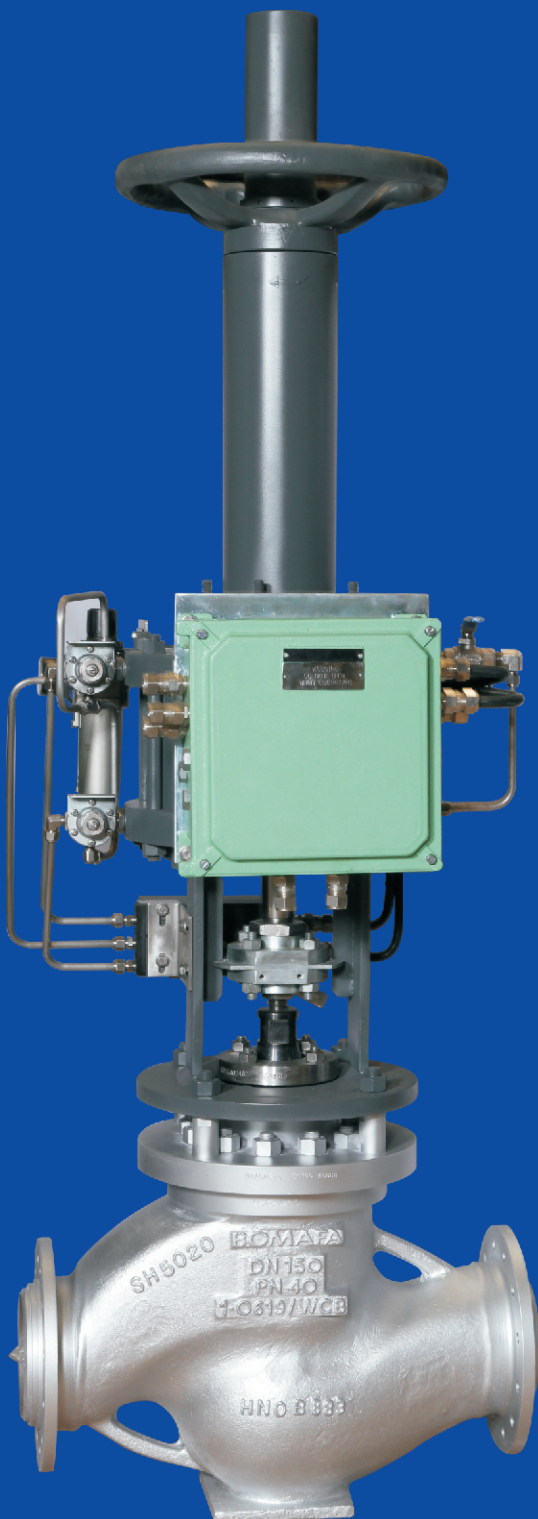

BOMAF[®]
Special Valve Solutions

- Heavy duty
- Hardened Trim
- Low Noise
- Easy Maintenance
- Controlled Velocity
- Anti Cavitation



Certificates

Zertifikat

Prof. System: **ISO 9001:2015**
 Zertifikat-Registrier-Nr.: 01 100 1309991

Umschreibung:

BOMAF A - Armaturen GmbH
 41599 Eschborn
 Deutschland
IAF-Annahmesystem Fertigung/Anpassung GmbH
 41599 Eschborn
 Deutschland

Geprüfte/r Person/Personen:
 Konzeption, Herstellung und Prüfung von Armaturenteilen, Komponenten, Montage und Prüfung von Schweißverbindungen, Verschleiß- und Hochdruck-Prüfung, Ablesen und Einstellen von Messgeräten, Energieverbrauch, Prozesskontrolle und -verbesserung.

Geprüft: Dieses Zertifikat ist gültig vom 27.10.2019 bis 27.10.2021.
 Es wurde verlängert am 27.10.2021.

27.10.2021

Zertifikat

Hersteller und Schweißbetrieb gemäß AD 2000-Regelwerk
 Zulassungs-Nr.: 01 204 404-1 5046

Hersteller: BOMAF A Armaturen GmbH
 41599 Eschborn

Hersteller und Schweißbetrieb: BOMAF A Armaturen GmbH
 41599 Eschborn

Geprüfte/r Person/Personen:

- Herstellung und Prüfung von Armaturenteilen, Komponenten, Montage und Prüfung von Schweißverbindungen
- Verschleiß- und Hochdruck-Prüfung, Ablesen und Einstellen von Messgeräten, Energieverbrauch, Prozesskontrolle und -verbesserung
- Herstellung von Hochdruck-Prüfung

Prüfungsort: AD 2000-Eschborn BFF 3
Prüfungstermin: 27.10.2019
Prüfungsbüro: BOMAF A Armaturen GmbH
 41599 Eschborn
Prüfungsbüro-Nr.: 02_Schweiß-302

Geprüft: 12. November 2019

Zertifikat

Überprüfung der schweißtechnischen Qualitätsanforderungen nach ISO 9894

Zertifikat-Nr.: 01 204 404-1 5046/1

Hersteller: BOMAF A Armaturen GmbH
 41599 Eschborn

Hersteller und Schweißbetrieb: BOMAF A Armaturen GmbH
 41599 Eschborn

Geprüfte/r Person/Personen:

- Herstellung und Prüfung von Armaturenteilen, Komponenten, Montage und Prüfung von Schweißverbindungen
- Verschleiß- und Hochdruck-Prüfung, Ablesen und Einstellen von Messgeräten, Energieverbrauch, Prozesskontrolle und -verbesserung
- Herstellung von Hochdruck-Prüfung

Prüfungsort: AD 2000-Eschborn BFF 3
Prüfungstermin: 27.10.2019
Prüfungsbüro: BOMAF A Armaturen GmbH
 41599 Eschborn
Prüfungsbüro-Nr.: 02_Schweiß-302

Geprüft: 12. November 2019

Zertifikat

Qualitätssicherungs-System nach Richtlinie 2014/68/EU

Zertifikat-Nr.: 01 204 404-1 5046/1

Hersteller: BOMAF A Armaturen GmbH
 41599 Eschborn

Hersteller und Schweißbetrieb: BOMAF A Armaturen GmbH
 41599 Eschborn

Geprüfte/r Person/Personen:

- Herstellung und Prüfung von Armaturenteilen, Komponenten, Montage und Prüfung von Schweißverbindungen
- Verschleiß- und Hochdruck-Prüfung, Ablesen und Einstellen von Messgeräten, Energieverbrauch, Prozesskontrolle und -verbesserung
- Herstellung von Hochdruck-Prüfung

Prüfungsort: AD 2000-Eschborn BFF 3
Prüfungstermin: 27.10.2019
Prüfungsbüro: BOMAF A Armaturen GmbH
 41599 Eschborn
Prüfungsbüro-Nr.: 02_Schweiß-302

Geprüft: 12. November 2019

Manufacturing facility in Germany



BOMAF WORLDWIDE



INTRODUCTION

Bomafa develops and produces optimum quality Control Valves for steam, gas and liquid applications. These valves are deployed in various segments of industries ranging from Power, Nuclear, Chemical and Petrochemical, Refineries, Sugar, Cement to name a few.

- Water control valves
- Feed water control valves
- Blowdown control valves
- Reheater spray control valves
- Attemperator spray control valves
- Superheater spray control valves
- Minimum flow pump re-circulation valves
- Steam Control valves
- Soot blower valves
- Steam pegging control valves
- Gas control valves

The construction is made in accordance with the requirements of modern techniques and of current prevailing statutory regulations as well!

Our working philosophy:

- Low noise designed valves
- Extreme short maintenance times thanks to easily removable internals
- High precision
- Widest options available and selected to meet stringent plant requirements
- Trim selection based on over 100 years of proven experience
- Balanced and unbalanced designs selected as per process conditions
- Proven high flow capacities available
- Rugged, compact, maintenance friendly double acting spring return Cylinder piston actuators provided

Features :

1. Bomafa Control valves are reliable and proven valves in most demanding conditions. These valves are built according to process conditions and offer trouble free operation for years to come is a testimony to the quality and soundness of design philosophy!
2. Trim with multi stage multi path for very high pressure drops.
3. Reduced noise levels
4. Balanced and unbalanced designs to suit each application
5. Interchangeability of the components reduce stock inventories
6. Trim supplied duly hardened stellited/plasma nitrided as per requirements
7. High rangeability of 50:1 available and for higher requirements consult plant
8. Installation friendly designs
9. Tight shut off available as per FCI 70 -2 class V seat leakage and MSS-SP-61.
10. Double acting piston cylinder actuators are provided as standard.
11. High flow capacities are proven and achieved

VALVE MODEL NUMBERING / DECODIFICATION

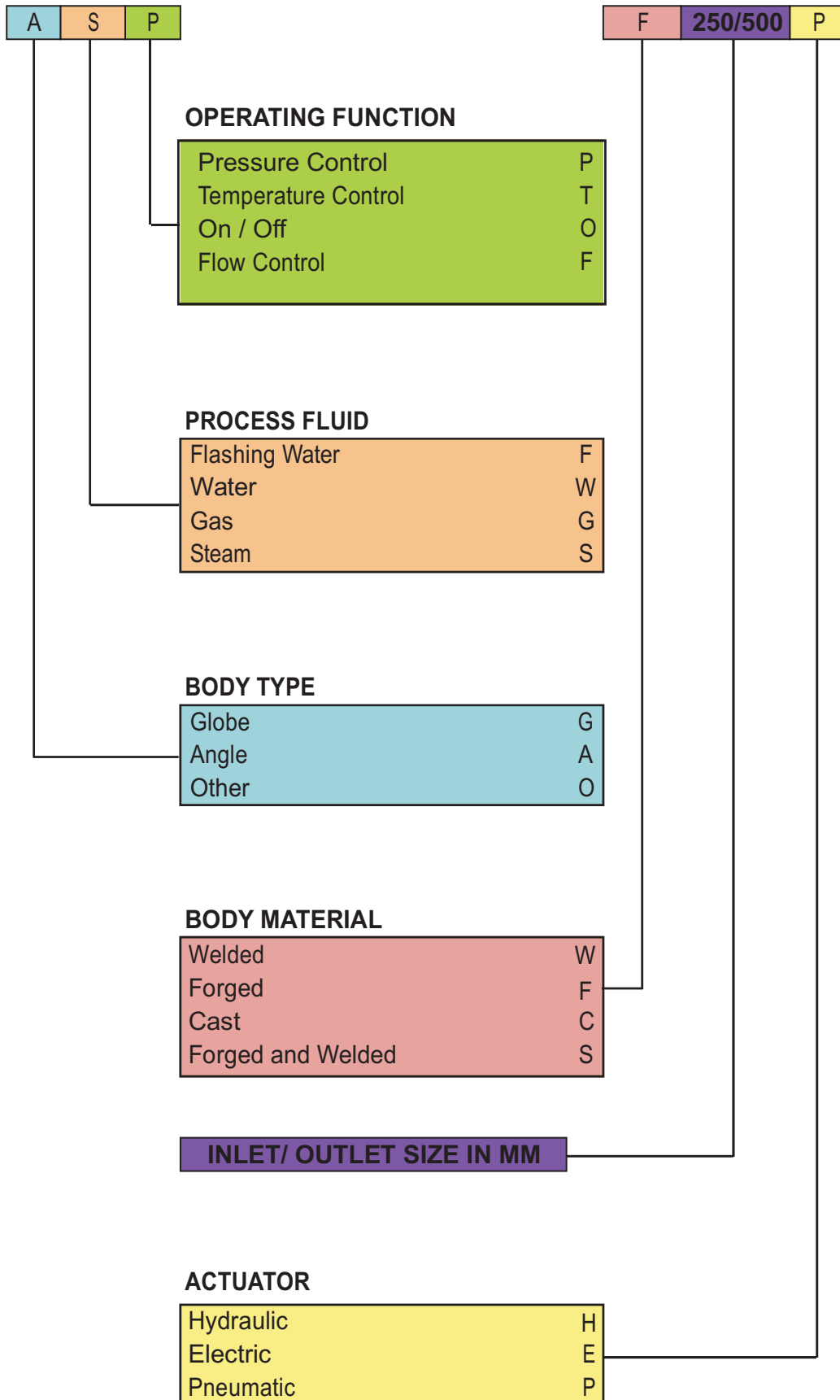

Pressure Class

Rating	Material
ASME	
150# thru 1500#	Cast (forged available on request)
2500# thru 4500# special	Forged construction
DIN	
PN 10 thru PN 250	Cast (forged available on request)
PN 315 thru PN 630	Forged construction

Material Selection

Component	Temperature	Material
Body / Bonnet	Up to 420°C	SA 216 WCB SA 216 WCC SA 105
	420°C thru 550°C	SA 217 WC6 SA 217 WC9 SA 182 F11 SA 182 F22
	> 550°C	SA 217 W12A SA 182 F91 SA 182 F92
Trim	Up to 420°C	SA 410 PL Nt SS 316 PL Nt
	> 420°C	DIN 1.4923 PL Nt/Inconel/Alloy steel PL Nt
Packing	Up to 420°C	PTFE
	> 420°C	Pure graphite

- Material transition available from SA 182 F92 to SA 105
- Any other body & bonnet material on request.
- Stellite trim SS 316 & DIN 1.4923 provided on request

Cv Table

Valve Size mm	Maximum Seat mm	Maximum Stroke mm	Maximum CV	Maximum Kv
25	25	25	10.42	8.90
40	37	25	25.02	21.39
50	47	50	36.60	33.85
80	67	75	87.59	74.86
100	98	100	183.72	157.03
150	126	125	292.56	250.05
200	166	150	555.03	474.38
250	225	200	1010.51	863.68

- Above Values are subject to change.
- For higher size consult factory

Sample out put – sizing software

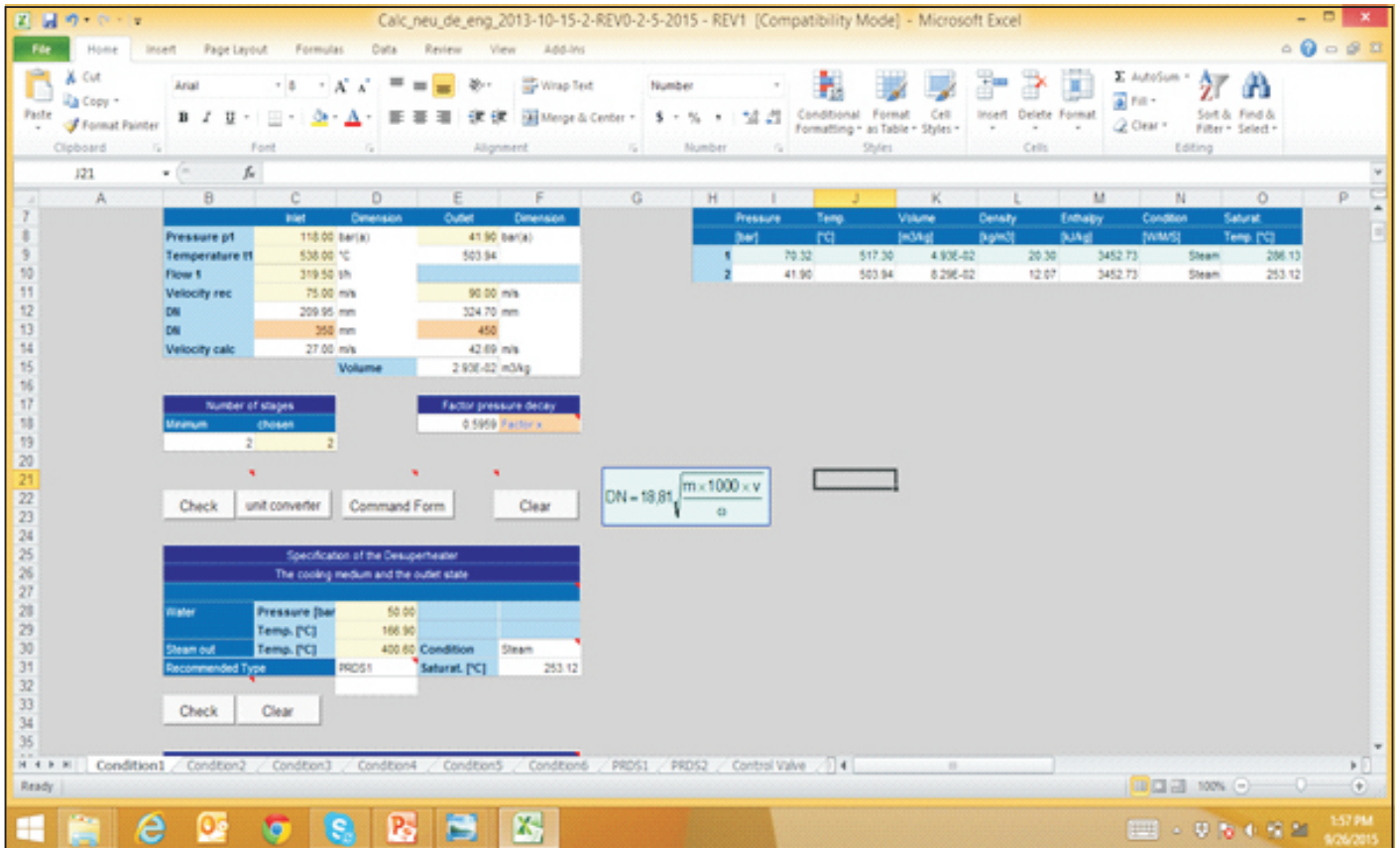

In-house CFD facilities

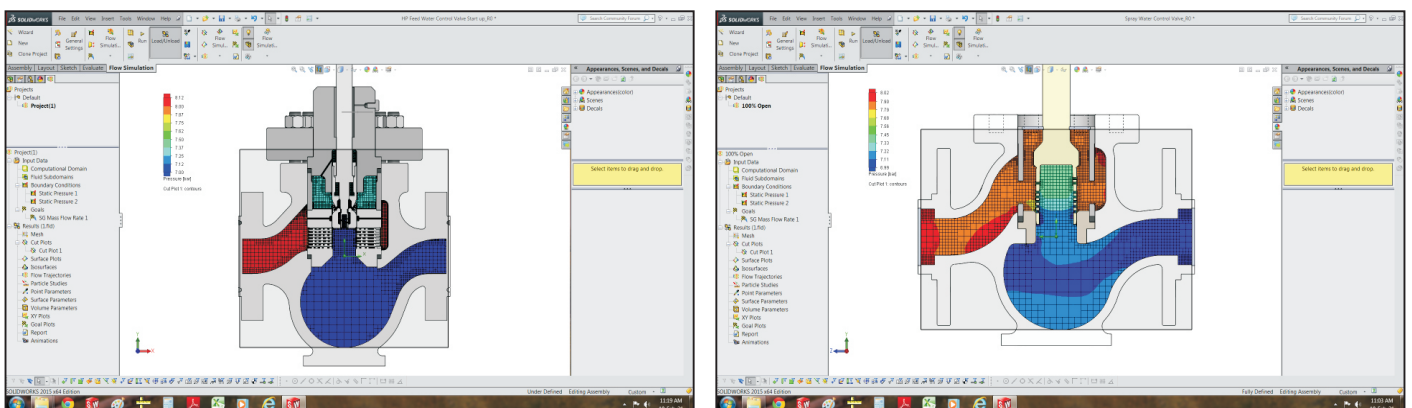

- This CFD facility assists in developing new designs
- This CFD facility also helps in validation before starting of manufacturing and thereby ensures timely completion and realistic deliveries are catered.

Trim Variations

- Characteristics: Linear , equal % , modified, special curves provided on request
- Flow direction : Generally flow to close (Optional flow to open)
to achieve Class V / Class VI seat leakage
- Spindle: unbalance up to 57mm seat diameter balance above 67mm seat diameter

Element design	
Avoiding vibration:	Heavy guided spindle Selection of adequate number of Stages. Adequate control of trim exit velocity / energy
Low noise:	Selection of adequate number of discrete pressure reducing stages controlling the noise at the source and not by attenuating it by means of noise insulation.
Easy maintenance:	Trim is easily replaceable Trim components are clamped between body & bonnet No welding in seat component.

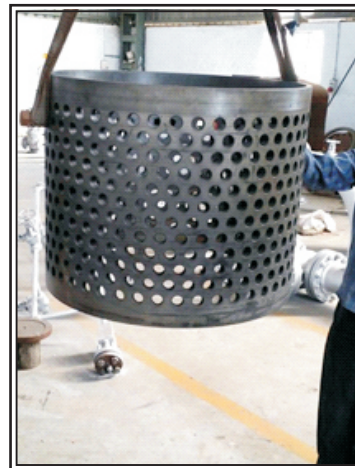
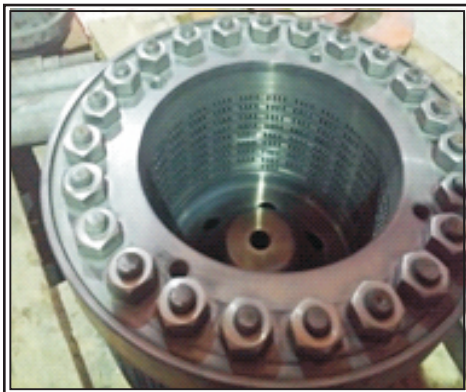

Steam :

- Pressure ratio across any stage > 0.546
- Advantages:
- Subcritical pressure drop across each stage.
 - Controlled velocity
 - Eliminating erosion
 - Controlled noise < 85 dBA for continuous & < 95 dBA for intermittent
 - Eliminates vibration
 - For continuous duty application trim exit energy < 480 kpa
 - For intermittent service trim exit energy < 1030 kpa

Water :

Bomafa controls the cavitation and erosion at source by special element design & controlling the velocity at trim exit - labyrinth trim

ISA Guide Lines:

Non flashing service - trim exit velocity < 30 m/sec
 For flashing service - trim exit velocity < 23 m/sec

Wide range of options to suit the most stringent and demanding applications

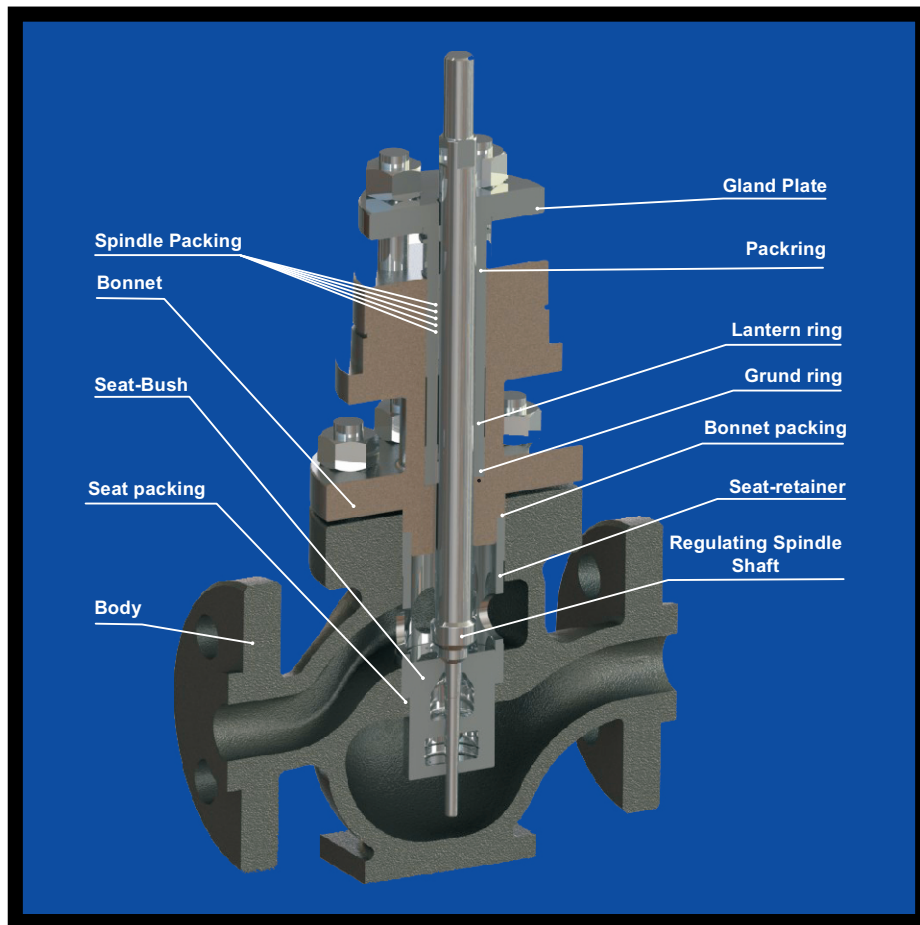

DOUBLE CONTOUR

- Two stage contour, parabolic unbalanced plug design can handle high pressure drop
- Can be used to control minimum Cv from 0.01 to 3.00
- Can provide valve up to 2"
- Provided in any trim material like: SS410, SS316, Inconel, Alloy steel and equivalent DIN grades.
- Heavy duty continuous top and bottom guide to avoid vibration across full range of operation
- Works well in anti-cavitation fluid.
- Hard facing plasma nitrided trim as standard
- Self-lubricating pure graphite packing as standard. Hence no lubrication is required during operation.
- Flow direction flow to close as standard helps in achieving and maintaining FCI 70-2 class V seat leakage during years of operation.
- As standard for non-flashing services trim exit velocity is maintained < 30 m/s
- As standard for flashing services trim exit velocity is maintained < 23 m/s
- As standard for intermittent steam and gaseous service trim exit energy is maintained < 1030 kpa
- As standard for continuous duty trim exit energy is maintained < 480 kpa
- For steam & gaseous services the pressure ratio is > 0.546 as standard across each stage

Wide range of options to suit the most stringent and demanding applications

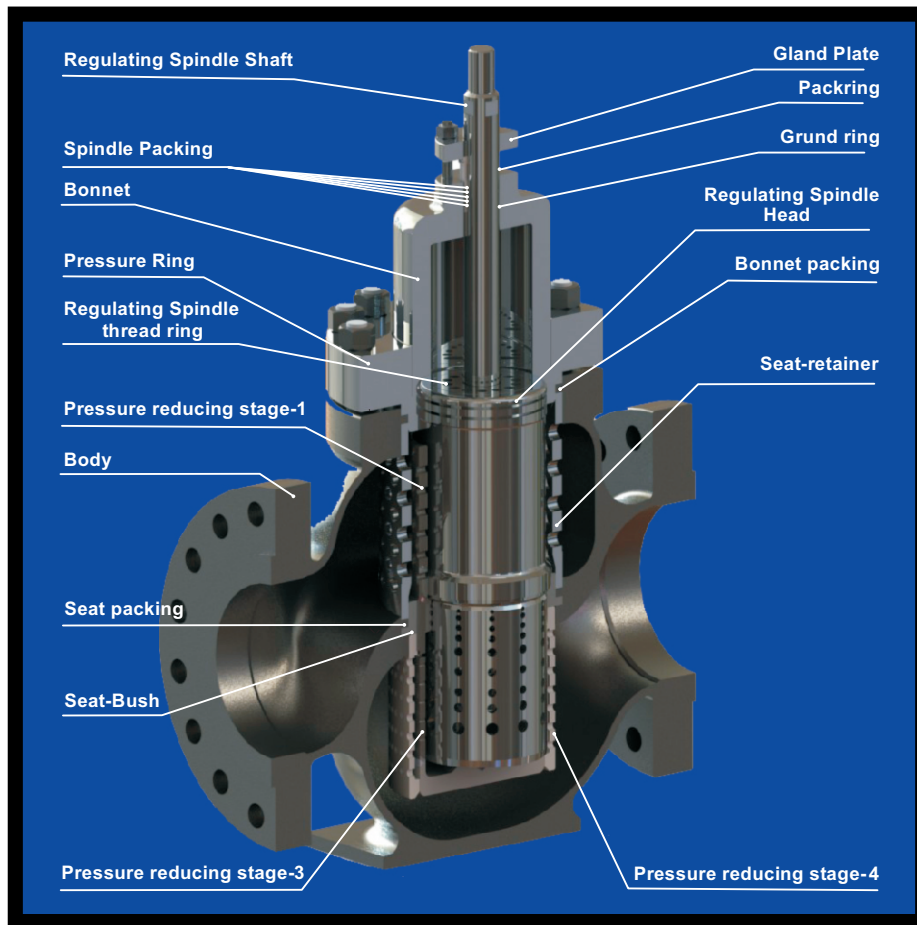

BALANCED SPINDLE WITH MULTI STAGE

- All four stages are fully control in a synchronized to have continuous four stage control across full range
- Valve size can be provided 3" and above
- Provided in any trim material like: SS410, SS316, Inconel, Alloy steel and equivalent DIN grades.
- Heavy duty continuous top and bottom guide to avoid vibration across full range of operation
- Works well in anti-cavitation fluid.
- Hard facing plasma nitrided trim as standard
- Self-lubricating pure graphite packing as standard. Hence no lubrication is required during operation.
- Flow direction flow to close as standard helps in achieving and maintaining FCI 70-2 class V seat leakage during years of operation.
- As standard for non-flashing services trim exit velocity is maintained $< 30 \text{ m/s}$
- As standard for flashing services trim exit velocity is maintained $< 23 \text{ m/s}$
- As standard for intermittent steam and gaseous service trim exit energy is maintained $< 1030 \text{ kpa}$
- As standard for continuous duty trim exit energy is maintained $< 480 \text{ kpa}$
- For steam & gaseous services the pressure ratio is > 0.546 as standard across each stage
- Multistage has enough no. of stages to eliminate erosion, cavitation, noise & vibration

Wide range of options to suit the most stringent and demanding applications

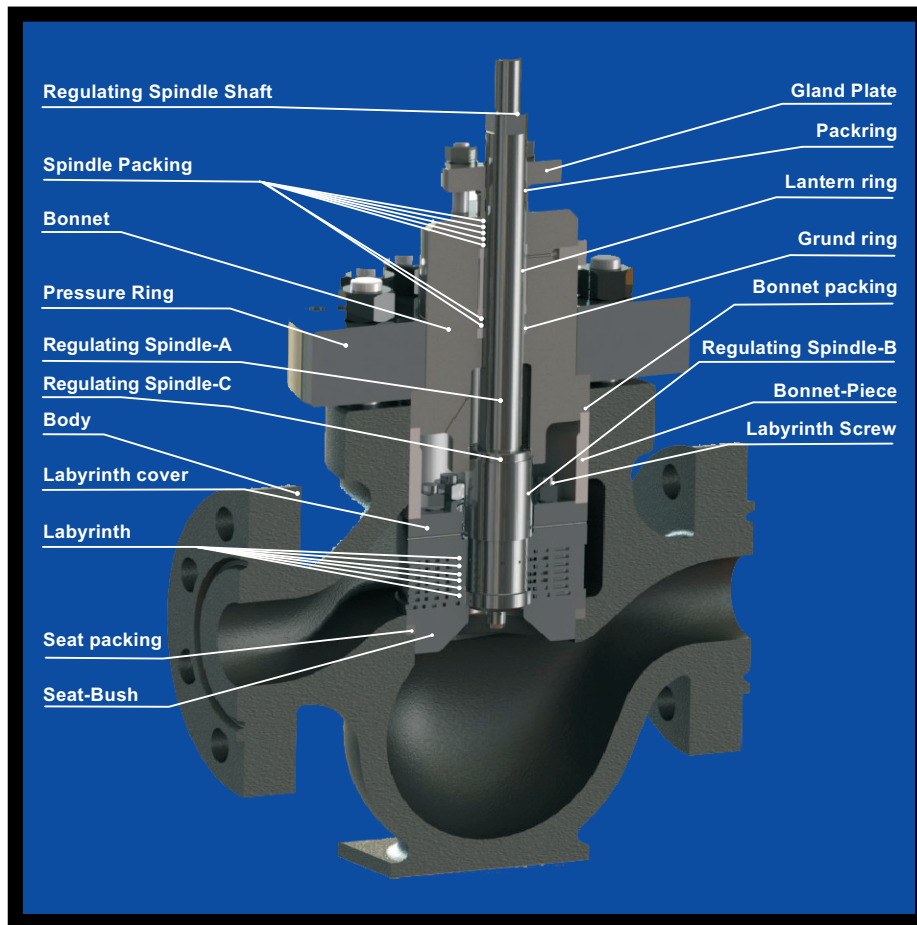

LABYRINTH + CONTOUR + DRILL

- Minimum Cv 0.1 and above Valve size 1" and above
- Minimum 2 stages and there is no limit for more number of stages
- Provided in any trim material like: SS410, SS316, Inconel, Alloy steel and equivalent DIN grades.
- Heavy duty continuous top and bottom guide to avoid vibration across full range of operation
- Works well in anti-cavitation fluid.
- Hard facing plasma nitrided trim as standard
- Self-lubricating pure graphite packing as standard. Hence no lubrication is required during operation.
- Flow direction flow to close as standard helps in achieving and maintaining FCI 70-2 class V seat leakage during years of operation.
- As standard for non-flashing services trim exit velocity is maintained < 30 m/s
- As standard for flashing services trim exit velocity is maintained < 23 m/s
- As standard for intermittent steam and gaseous service trim exit energy is maintained < 1030 kpa
- As standard for continuous duty trim exit energy is maintained < 480 kpa
- For steam & gaseous services the pressure ratio is > 0.546 as standard across each stage
- Multipath has enough no. of stages to eliminate erosion, cavitation, noise & vibration

Wide range of options to suit the most stringent and demanding applications

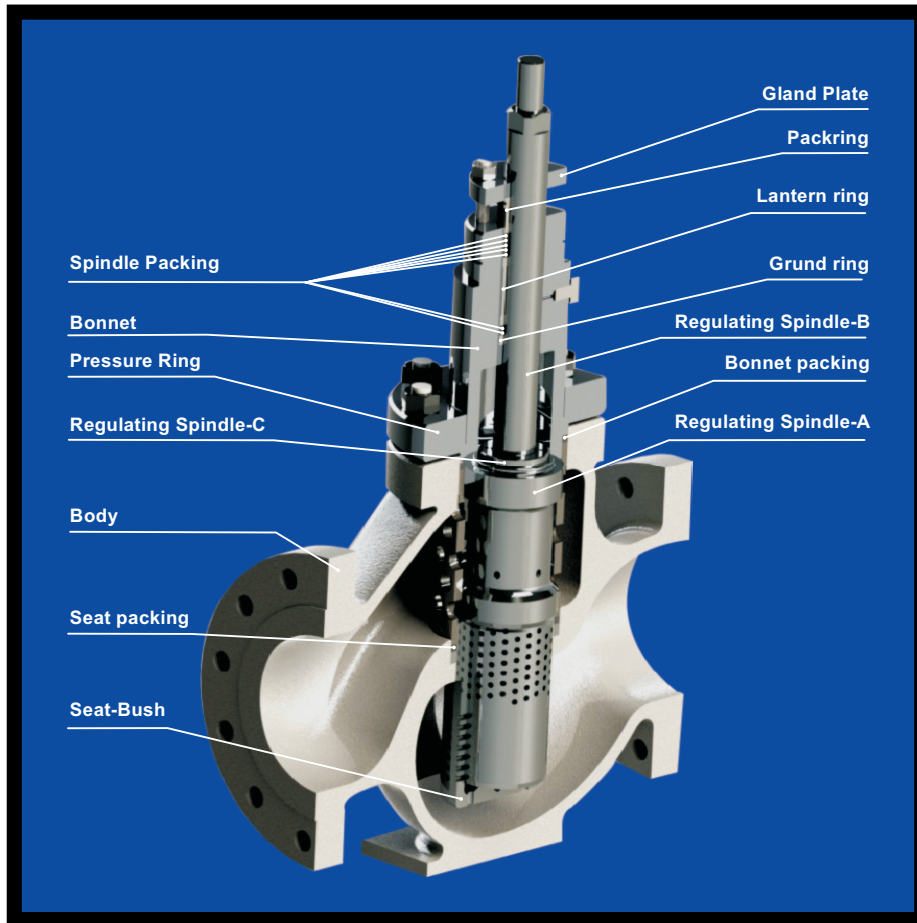

CONTOUR + 3 STAGE DRILL

- Both drill cone plug are synchronized to have continuous 2 stage control across full range. Valve size 4" and above
- Provided in any trim material like: SS410, SS316, Inconel, Alloy steel and equivalent DIN grades.
- Heavy duty continuous top and bottom guide to avoid vibration across full range of operation
- Works well in anti-cavitation fluid.
- Hard facing plasma nitrided trim as standard
- Self-lubricating pure graphite packing as standard. Hence no lubrication is required during operation.
- Flow direction flow to close as standard helps in achieving and maintaining FCI 70-2 class V seat leakage during years of operation.
- As standard for non-flashing services trim exit velocity is maintained < 30 m/s
- As standard for flashing services trim exit velocity is maintained < 23 m/s
- As standard for intermittent steam and gaseous service trim exit energy is maintained < 1030 kpa
- As standard for continuous duty trim exit energy is maintained < 480 kpa
- For steam & gaseous services the pressure ratio is > 0.546 as standard across each stage
- Multistage has enough no. of stages to eliminate erosion, cavitation, noise & vibration

Wide range of options to suit the most stringent and demanding applications

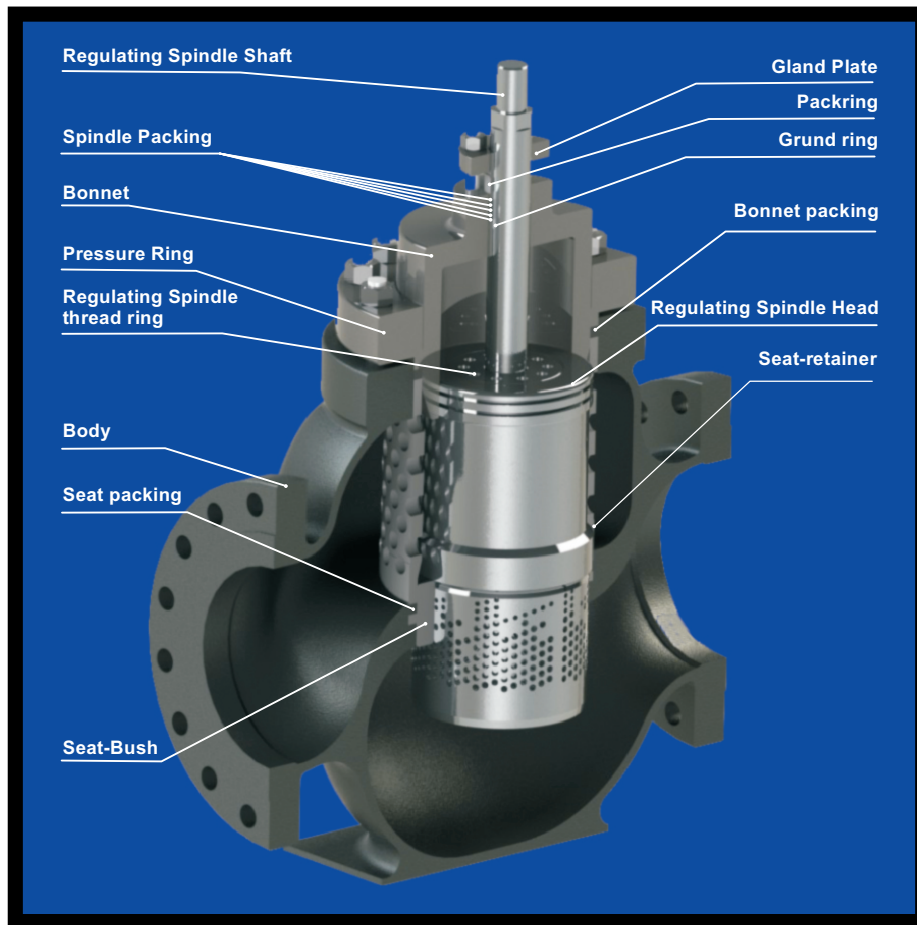

BALANCED SPINDLE SINGLE STAGE

- Applies to valve sizes 3" and above
- Single stage perforated plug can handle high pressure drop.
- Pilot balanced design reduces the actuator forces thereby making valve & actuator compact
- The piston ring being of metal hardened material of DIN 1.4086 can be used for multimillion operations.
- Provided in any trim material like: SS410, SS316, Inconel, Alloy steel and equivalent DIN grades.
- Heavy duty continuous top and bottom guide to avoid vibration across full range of operation
- Works well in anti-cavitation fluid.
- Hard facing plasma nitrided trim as standard
- Self-lubricating pure graphite packing as standard. Hence no lubrication is required during operation.
- Flow direction flow to close as standard helps in achieving and maintaining FCI 70-2 class V seat leakage during years of operation.
- As standard for non-flashing services trim exit velocity is maintained < 30 m/s
- As standard for flashing services trim exit velocity is maintained < 23 m/s
- As standard for intermittent steam and gaseous service trim exit energy is maintained < 1030 kpa
- As standard for continuous duty trim exit energy is maintained < 480 kpa
- For steam & gaseous services the pressure ratio is > 0.546 as standard across each stage
- Drill cone helps to reduce noise at source

Wide range of options to suit the most stringent and demanding applications

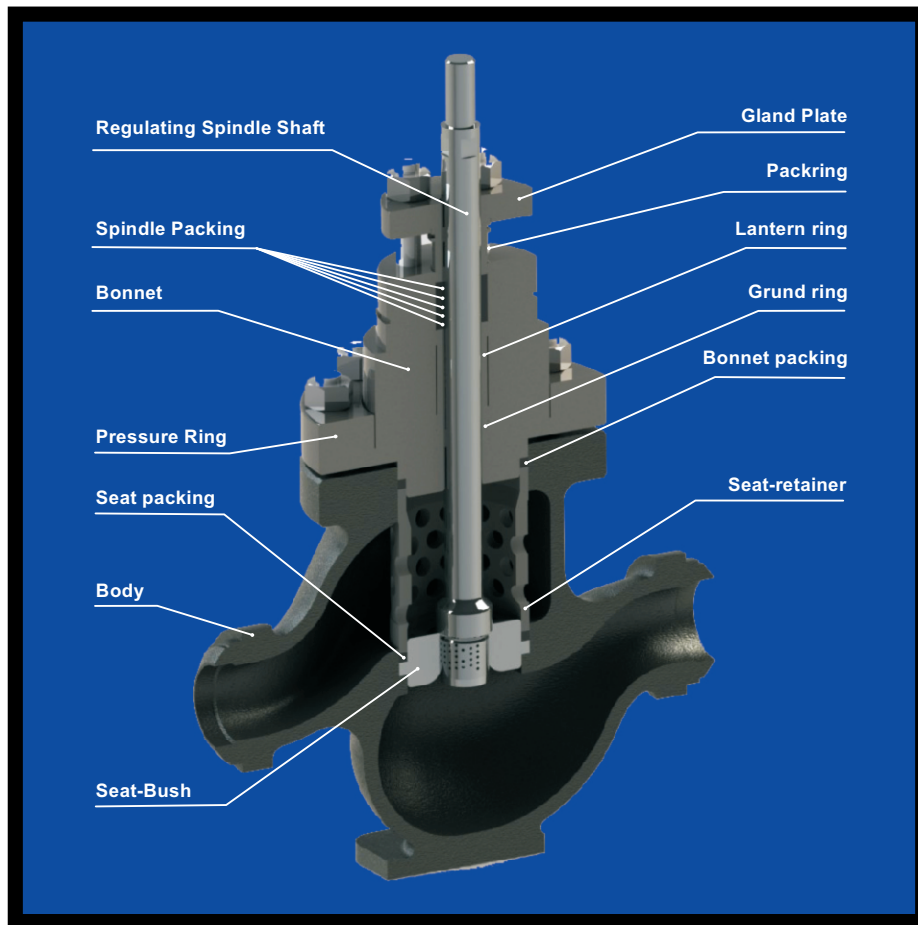

UNBALANCED SINGLE STAGE

- Single stage perforated plug can handle high pressure drop.
- Can provide valve size 1" and above Provided in any trim material like: SS410, SS316, Inconel, Alloy steel and equivalent DIN grades.
- Heavy duty continuous top and bottom guide to avoid vibration across full range of operation
- Works well in anti-cavitation fluid.
- Hard facing plasma nitrided trim as standard
- Self-lubricating pure graphite packing as standard.
- Hence no lubrication is required during operation.
- Flow direction flow to close as standard helps in achieving and maintaining FCI 70-2 class V seat leakage during years of operation.
- As standard for non-flashing services trim exit velocity is maintained < 30 m/s
- As standard for flashing services trim exit velocity is maintained < 23 m/s
- As standard for intermittent steam and gaseous service trim exit energy is maintained < 1030 kpa
- As standard for continuous duty trim exit energy is maintained < 480 kpa
- For steam & gaseous services the pressure ratio is > 0.546 as standard across each stage
- Small perforation in drill cone helps to reduce noise at source

Wide range of options to suit the most stringent and demanding applications

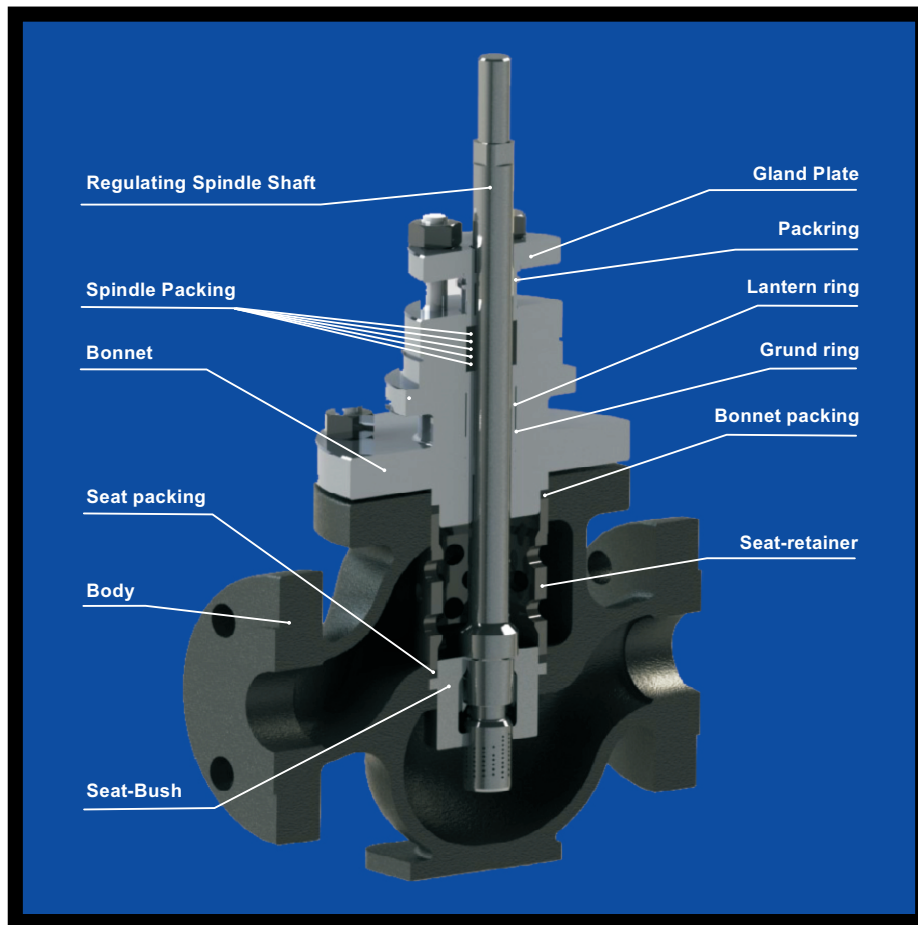

UNBALANCED CONTOUR(PARABOLIC) + DRILL(PERFORATED)

- 2 Stage contour and drill cone can handle large pressure drop
- Can be used to control minimum Cv of 3
- Both parabolic and perforated plug are synchronized to have continuous 2 stage control across full range of travel
- Provided in any trim material like: SS410, SS316, Inconel, Alloy steel and equivalent DIN grades.
- Heavy duty continuous top and bottom guide to avoid vibration across full range of operation
- Works well in anti-cavitation fluid.
- Hard facing plasma nitrided trim as standard
- Self-lubricating pure graphite packing as standard. Hence no lubrication is required during operation.
- Flow direction flow to close as standard helps in achieving and maintaining FCI 70-2 class V seat leakage during years of operation.
- As standard for non-flashing services trim exit velocity is maintained < 30 m/s
- As standard for flashing services trim exit velocity is maintained < 23 m/s
- As standard for intermittent steam and gaseous service trim exit energy is maintained < 1030 kpa
- As standard for continuous duty trim exit energy is maintained < 480 kpa
- For steam & gaseous services the pressure ratio is > 0.546 as standard across each stage
- Parabolic + perforated helps to reduce noise at source

DIMENSIONS

FACE TO FACE DIMENSIONS FOR INTEGRAL FLANGE GLOBE-STYLE CONTROL VALVE-ANSI/ISA-75.08.01

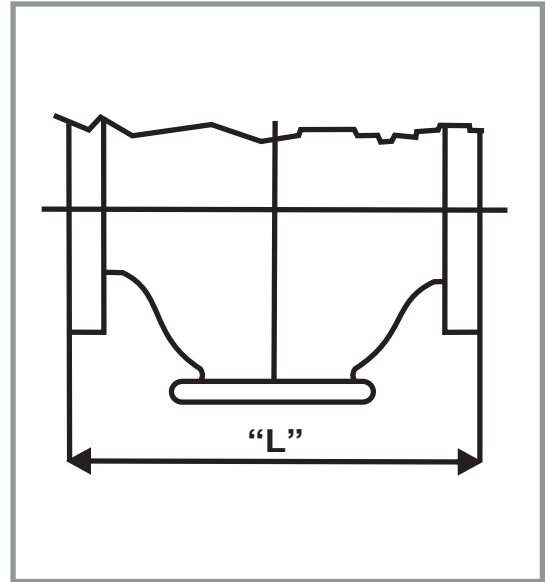
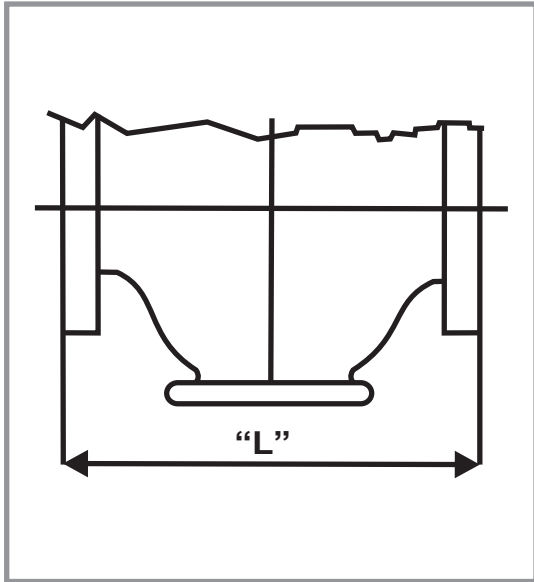

NOMINAL VALVE SIZE		PN 20 (CLASSES 125 AND 150)		PN 50 (CLASSES 250 AND 300)		PN 110 (CLASS 600)		TOLERANCE	
		DIMENSION "L"		DIMENSION "L"		DIMENSION "L"		DIMENSION "L"	
mm	INCHES	mm	INCHES	mm	INCHES	mm	INCHES	mm	INCHES
25	1	184	7.25	197	7.75	210	8.25	± 1.6	± 0.062
40	1-1/2"	222	8.75	235	9.25	251	9.88	± 1.6	± 0.062
50	2	254	10.00	267	10.50	286	11.25	± 1.6	± 0.062
65	2-1/2"	276	10.88	292	11.50	311	12.25	± 1.6	± 0.062
80	3	298	11.75	318	12.50	337	13.25	± 1.6	± 0.062
100	4	352	13.88	368	14.50	394	15.50	± 1.6	± 0.062
150	6	451	17.75	473	18.62	508	20.00	± 1.6	± 0.062
200	8	543	21.38	568	22.38	610	24.00	± 1.6	± 0.062
250	10	673	26.50	708	27.88	752	29.62	± 1.6	± 0.062
300	12	737	29.00	775	30.50	819	32.25	± 3.2	± 0.125
350	14	889	35.00	927	36.50	972	38.25	± 3.2	± 0.125
400	16	1016	40.00	1057	41.62	1108	43.62	± 3.2	± 0.125

NOTE : 1) FOR LARGE SIZES CONTACT FACTORY.

2) CONTACT FACTORY FOR FACE TO FACE AND END TO END DIMENSTIONS OF VALVE AS PER ASME B 16.10

DIMENSIONS

FACE TO FACE DIMENSIONS FOR SOCKET WELD-END GLOBE-STYLE CONTROL VALVE-ANSI/ISA-75.08.03

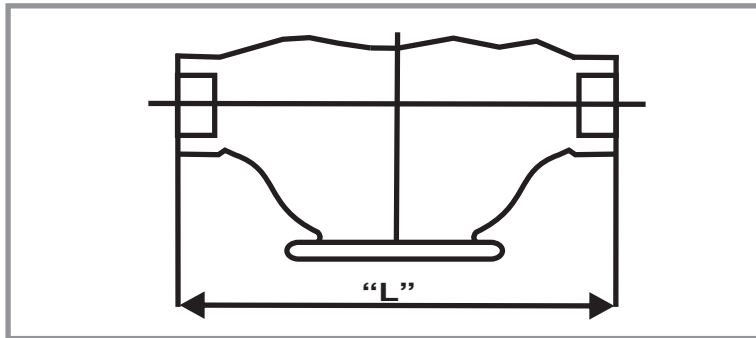

NOMINAL VALVE SIZE		PN 20, 50, & 100		PN 150 & 250		PN 420		TOLERANCE	
		(CLASSES 150, 300, & 600)		(CLASSES 900 & 1500)		(CLASS 2500)		DIMENSION "L"	
		DIMENSION "L"		DIMENSION "L"		DIMENSION "L"			
mm	INCHES	mm	INCHES	mm	INCHES	mm	INCHES	mm	INCHES
25	1	210	8.25	279	11.00	318	12.50	± 6.4	± 0.025
40	1-1/2"	251	9.88	330	13.00	381	15.00	± 6.4	± 0.025
50	2	286	11.25	375	14.75	400	15.75	± 6.4	± 0.025

FACE TO FACE DIMENSIONS FOR BUTT WELD-END GLOBE-STYLE CONTROL VALVE-ANSI/ISA-75.08.04

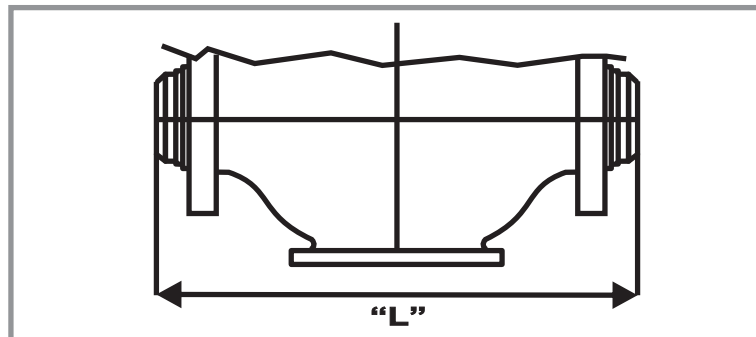

NOMINAL VALVE SIZE		(CLASSES 4500)		TOLERANCE	
		DIMENSION "L"		DIMENSION "L"	
mm	INCHES	mm	INCHES	mm	INCHES
25	1	298	11.75	± 1.6	± 0.062
40	1-1/2"	298	11.75	± 1.6	± 0.062
50	2	378	14.88	± 1.6	± 0.062
80	3	479	18.88	± 1.6	± 0.062
100	4	584	23.00	± 1.6	± 0.062
150	6	883	34.75	± 2.4	± 0.093
200	8	1118	44.00	± 2.4	± 0.093

NOTE : 1) FOR LARGE SIZES CONTACT FACTORY.

2) CONTACT FACTORY FOR FACE TO FACE AND END TO END DIMENSIONS OF VALVES AS PER ASME B 16.10

DIMENSIONS

FACE TO FACE DIMENSIONS FOR BUTTWELD-END GLOBE-STYLE CONTROL VALVE-ANSI/ISA-75.08.05

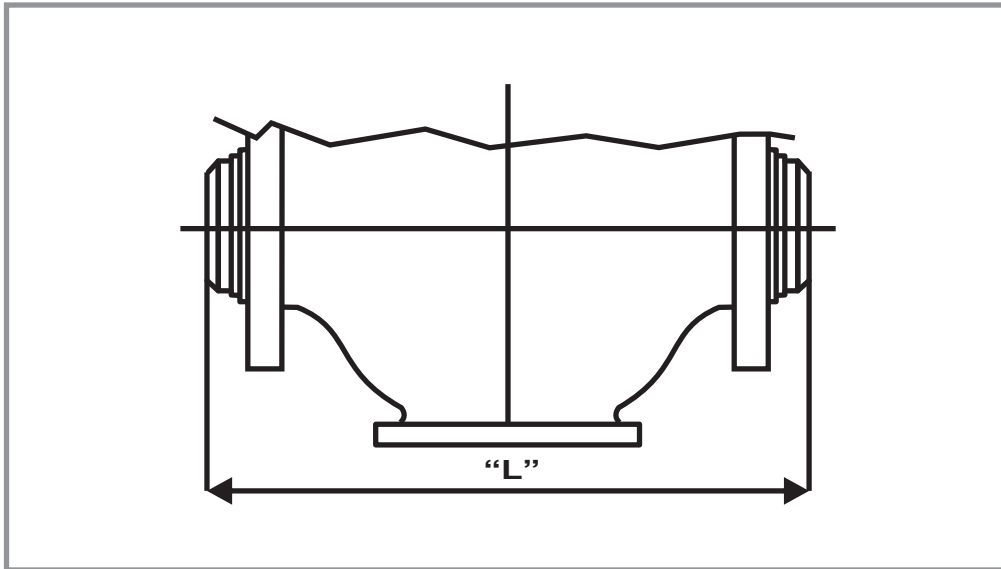

NOMINAL VALVE SIZE		PN 20, 50, & 100		PN 150 & 250		PN 420		TOLERANCE	
		(CLASSES 150, 300, & 600)		(CLASSES 900 & 1500)		(CLASS 2500)		DIMENSION "L"	
		DIMENSION "L"		DIMENSION "L"		DIMENSION "L"			
mm	INCHES	mm	INCHES	mm	INCHES	mm	INCHES	mm	INCHES
25	1	210	8.25	279	11.50	318	12.50	± 1.6	± 0.062
40	1-1/2"	251	9.88	330	13.12	359	14.12	± 1.6	± 0.062
50	2	286	11.25	375	14.75	400	15.75	± 1.6	± 0.062
65	2-1/2"	311	12.25	375	14.75	400	15.75	± 1.6	± 0.062
80	3	337	13.25	460	18.12	498	19.62	± 1.6	± 0.062
100	4	394	15.50	530	20.87	575	22.62	± 1.6	± 0.062
150	6	508	20.00	768	30.25	819	32.25	± 1.6	± 0.062
200	8	610	24.00	832	32.75	1029	40.25	± 1.6	± 0.062
250	10	752	29.62	991	39.00	1270	50.00	± 1.6	± 0.062
300	12	819	32.35	1130	44.50	1422	56.00	± 3.2	± 0.125
350	14	1029	40.50	1257	49.50	1803	71.00	± 3.2	± 0.125
400	16	1108	43.62	1422	56.00			± 3.2	± 0.125
450	18			1727	68.00			± 3.2	± 0.125

NOTE : 1) FOR LARGE SIZES CONTACT FACTORY.

2) CONTACT FACTORY FOR FACE TO FACE AND END TO END DIMENSIONS OF VALVES AS PER ASME B 16.10

DIMENSIONS

FACE TO FACE DIMENSIONS FOR FLANGED GLOBE-STYLE CONTROL VALVE-ANSI/ISA-75.08.06

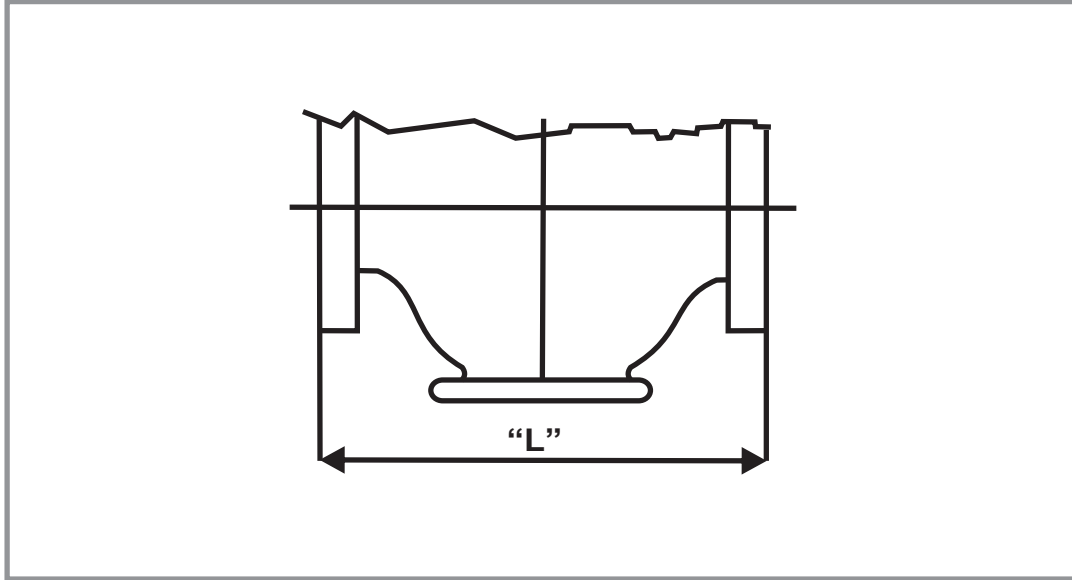

NOMINAL VALVE SIZE		PN 150 (CLASS 900)		PN 250 (CLASS 1500)		PN 420 (CLASS 2500)		TOLERANCE	
		DIMENSION "L"		DIMENSION "L"		DIMENSION "L"		DIMENSION "L"	
mm	INCHES	mm	INCHES	mm	INCHES	mm	INCHES	mm	INCHES
25	1	292	11.50	292	11.50	318	12.50	± 1.6	± 0.062
40	1-1/2"	333	13.12	333	13.12	381	15.00	± 1.6	± 0.062
50	2	375	14.75	375	14.75	400	16.25	± 1.6	± 0.062
65	2-1/2"	410	16.12	410	16.12	441	17.38	± 1.6	± 0.062
80	3	441	17.38	460	18.12	660	26.00	± 1.6	± 0.062
100	4	511	20.12	530	20.87	737	29.00	± 1.6	± 0.062
150	6	714	28.12	768	30.25	864	34.00	± 1.6	± 0.062
200	8	914	36.00	972	38.25	1022	40.25	± 1.6	± 0.062
250	10	991	39.00	1067	42.00	1372	54.00	± 1.6	± 0.062
300	12	1130	44.50	1219	48.00	1575	62.00	± 3.2	± 0.125
350	14	1257	49.50	1257	49.50			± 3.2	± 0.125
400	16	1422	56.00	1422	56.00			± 3.2	± 0.125
450	18	1727	68.00	1727	68.00			± 3.2	± 0.125

NOTE : 1) FOR LARGE SIZES CONTACT FACTORY.

2) CONTACT FACTORY FOR FACE TO FACE AND END TO END DIMENSIONS OF VALVES AS PER ASME B 16.10

Generation of Megawatts a dream? Try Bomafa Valves!



BOMAF A[®]
Special Valve Solutions

BOMAF A Oil & Gas GmbH
Hohensteinstr. 52
44866 Bochum, Germany
E-Mail: sales@bomafa.eu
Web: www.bomafa.eu